

COMPACT[®]
AUTOMATION PRODUCTS

Ball Slides

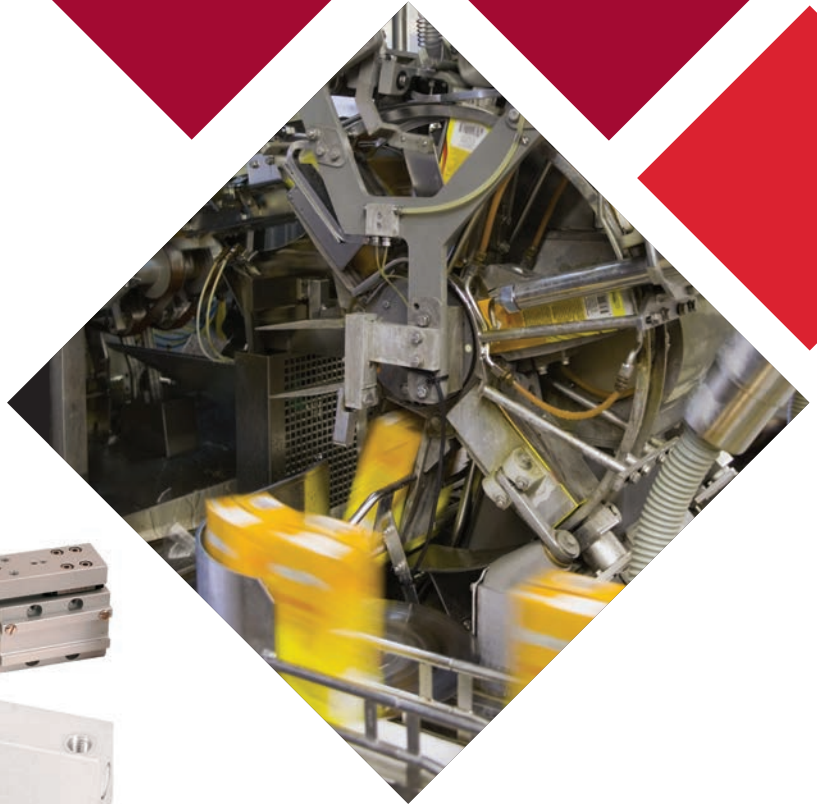
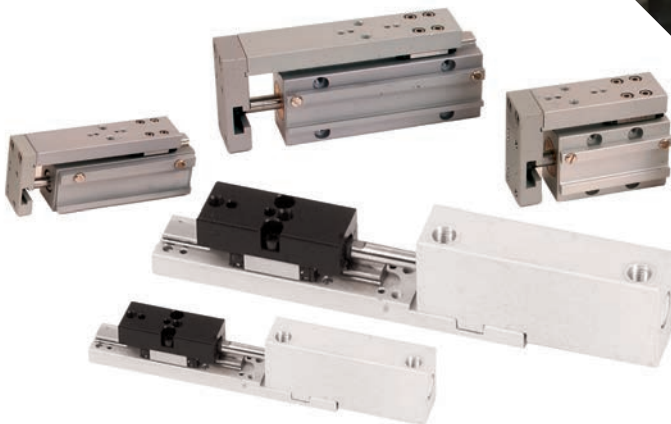

Ball Slide Cylinders: Table of Contents

Ball Slide Cylinders:

Forces/Pressure Ratings	pg. 2
How to Order.....	pg. 3
Component Description.....	pg. 4

Dimensions

BSC1000 Series	pg. 5-10
Technical Information	pg. 11

BSC2000 Series	pg. 12-27
Technical Information	pg. 28-29

Accessories/Options	pg. 30-36
---------------------------	-----------

Special Conditions and Limited Warranty	pg. 37
---	--------

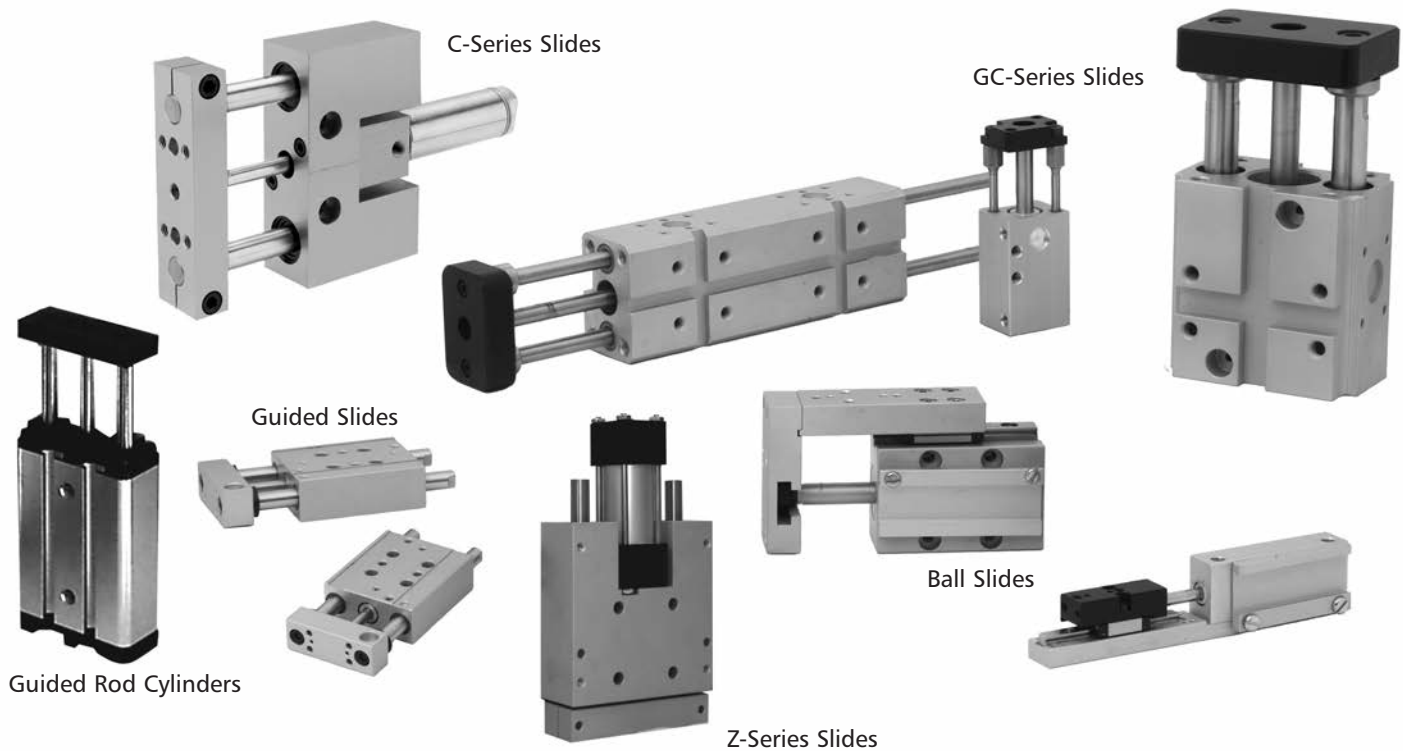

Slide Series Family

Introduction: Ball Slide Cylinders

Product Types

BSC1000 Series

Unique extra slim design puts the load bearing slide element in front of the air cylinder with a ridged support bracket.

- Bore Sizes (mm): 8, 12, 20, 25, 40
- 5 Models



BSC2000 Series

Extra short design puts the load bearing slide element next to the air cylinder. The 'L' shaped tooling plate offers various mounting options.

- Bore Sizes (mm): 8, 12, 20, 25, 40
- 15 Models



Force/Pressure Ratings

Bore	Piston Area mm ² (in ²)		Pre-Calculated Force in kgf (lbf)			
			4 BAR	6 BAR	7 BAR	10 BAR
8	Push	50 (.08)	2,04 (4.5)	3,1 (7)	3,6 (8)	NA
	Pull	37 (.06)	1,5 (3)	2,3 (5)	2,6 (6)	NA
12	Push	113 (.17)	4,6 (10)	6,9 (15)	8,1 (17)	11,5 (25.4)
	Pull	85 (.13)	3,5 (8)	5,2 (11)	6,1 (13)	8,7 (19.1)
20	Push	314 (.49)	12,8 (28)	19,2 (42)	22,4 (49)	32,0 (70.6)
	Pull	263 (.40)	10,7 (23)	16,1 (35)	18,8 (41)	26,9 (59.3)
25	Push	491 (.76)	15,0 (33.1)	30,0 (66.2)	40,1 (88.3)	50,1 (110.4)
	Pull	412 (.64)	12,6 (27.8)	25,2 (55.6)	33,6 (74.1)	42,0 (92.6)
40	Push	1257 (1.94)	38,5 (84.8)	76,9 (169.6)	102,6 (226.1)	128,2 (282.7)
	Pull	1056 (1.64)	32,3 (71.2)	64,6 (142.5)	86,2 (190.0)	107,7 (237.5)

Pressure Rating BAR (PSI)	
Pneumatic	Hydraulic*
8 (117)	-
8 (117)	-
15 (217)	30* (435)
15 (217)	30* (435)
15 (217)	30* (435)

*NOTE: With Hydraulic option
See 'Hydraulic Seals' page 32

Conversion Formulas:

1 Bar = 0,0102 kgf/mm² = 14.5 PSI

1 kgf = 2,2046 lbf

Example:

4 Bar x .0102 = ,0408 kgf/mm²

0,0408 kgf/mm² x 50 mm² = 2,04 kgf

2,04 kgf x 2.2046 = 4.5 lbf

How to Order: Ball Slide Cylinders

BSC Series Example: BSC2T20x25-PC3

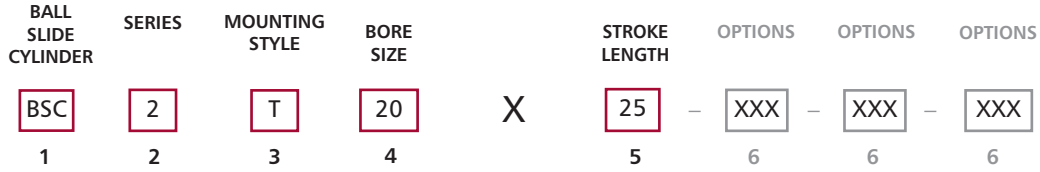

1 Style	
BSC	Ball Slide Cylinder

2 Series	
1	1000 Series
2	2000 Series

3 Mounting Style (2000 Series Only)	
S	End Mount
B	Base Mount
T	Thin Side Mount

Note: 1000 Series Mounting Style Blank

4 Bore	
8	8 mm
12	12mm
20	20mm
25	25mm

5 Bore	Stroke
8	2,5 5 7,5 10 12,5 15 17,5 20 22,5 25 27,5 30
12	2,5 5 7,5 10 12,5 15 17,5 20 22,5 25 27,5 30 32,5 35 37,5 40 42,5 45 47,5 50
20	5 10 15 20 25 30 35 40 45 50 55 60 65 70 75
25	5 10 15 20 25 30 35 40 45 50 55 60 65 70 75 80 85 90 95 100 105 110 115 120 125 130 135 140 145 150
40	5 10 15 20 25 30 35 40 45 50 55 60 65 70 75 80 85 90 95 100 105 110 115 120 125 130 135 140 145 150 155 160 165 170 175 180 185 190 195 200

6 Options	
MPA	Multi-Position (specify 1st stroke length)
MPA	Multi-Piston (specify stroke length)
PC1	Flow control on head end only
PC2	Flow control on cap end only
PC3	Flow control on both ends
18 NPT	1/8" National Pipe Thread*
HYD	Hydraulic seals**

*NOTE: Only available on 25 and 40mm bore.

**NOTE: Only available on 20, 25 and 40mm bore.

***NOTE: See page 30 for MPA details.

Component Description: Ball Slide Cylinders

BSC series cylinders are another variation of our versatile compact air cylinder. All models feature our signature compact space efficiency. We have combined our cylinders with a high load bearing, factory matched recirculating ball slide rail set in two simple, low cost, designs ideal for precision industrial automation.

Ball Slide Elements Smooth, quiet operating, recirculating ball slides are factory matched set assemblies with uniform, non-adjustable pre-load. Under load the slide assemblies feel smooth. With zero load the recirculation of the balls is felt.

Tooling Plate Aluminum tooling plates have machined surfaces with mounting patterns that match similar BSC units for multi-axis motion. Locator dowel pin holes are standard.

Mounting Surfaces Precision mounting surface with dowel pin locator holes are featured. Dowel pin holes are slip fit for m6 class pins on all surfaces.

Sensors All BSC Series units are sensor ready. Comtronic® limit sensors are sold **separately** in NPN and PNP variations.

Materials Basic materials include anodized aluminum, stainless steel slide elements, bronze or PET cylinder rod bushings, Nitrile seals and steel fasteners. Consult factory for harsh environment options including 100% stainless steel.

Design Tips

Temperature Limits All units are rated from 0° to 100°C continuous, to 120°C intermittently. For service over 100°C continuous — consult factory.

Loads Detailed moment load information is included. The Ball Slide Cylinders allow increased load capacity compared to a guide rod air cylinder. This is desirable for long, service-free life and lasting precision motion.

The rolling load inertia is most destructive to this device and must be accounted for in your design.

Lubrication

- **Cylinder** - The cylinder is factory lubricated and does not require air line induced lubrication, although additional air line lubrication is not a problem. Lubricated air that is compatible with petroleum based grease containing Teflon® will enhance the life of the cylinder. Non-lubricated air is acceptable to operate the cylinder.
- **Ball Slides** - All ball slide elements are factory lubricated. Periodic lubrication is required for maximum life expectancy. General guidelines and recommendations from the ball slide manufacturer: No. 2 lithium soap based grease, generously applied every six months to the rail and into the holes on the carriage.

Engineering Data

Pneumatic

Some type of control is **required** on any pneumatic ball slide cylinder, below are available choices.

8mm and 12mm Bore

Cylinders feature our patented Snap-Cap® design: a resilient retainer seal that aids in absorbing minor piston impact.

- **Flow Controls** are strongly recommended for all ball slides. Controlled speed extends life.

20mm, 25mm and 40mm Bore

Cylinders feature our patented stainless steel wire form end cap retainer.

- **Flow Controls** are strongly recommended for all ball slides. Controlled speed extends life.



CAUTION! USERS' DESIGN RESPONSIBILITIES

- **Mechanical Stops** External mechanical stops maximize unit life by reducing stresses caused when the cylinder bottoms out. High impact forces will damage the cylinder.
- **Shock Absorbers** If flow controls cannot be used, due to high cycle speeds, mechanical stops with external hydraulic shock absorbers will maximize unit life.



WARNING!

With high load capacities of the ball slide units, the forces resulting from inertia must be considered in your design.

BSC1000 Series

Pneumatic Cylinder

8 mm, 12mm, 20mm, 25mm and 40mm Bore
Slim 'In Line' Design



General Information

- Recirculating ball type slide, factory matched
- Side porting
- Sensor ready
- Multi-axis applications - no transition plates required
- Stroke lengths (mm):
 - > 8mm bore: 2,5-30
 - > 12mm bore: 2,5-50
 - > 20mm bore: 5-75
 - > 25mm bore: 5-150
 - > 40mm bore: 5-200
- Multi-position and Multi-piston cylinders
- Modifications welcome. Consult factory.

Available in 5 models

8mm Bore	Thin mount
12mm Bore	Thin mount
20mm Bore	Thin mount
25mm Bore	Thin mount
40mm Bore	Thin mount

NOTE: Multi-position and Multi-piston design shown in MPA section

Part number shown:
BSC112x30

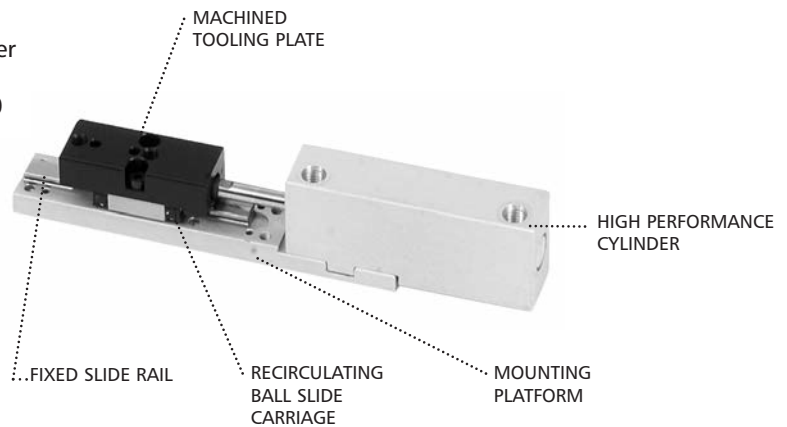

WARNING!

Pressurizing actuated equipment creates pinch points.

Prevent operator access to moving equipment and work pieces.



WARNING!

Mounting hardware must not interfere with ball slide function.

Disassembly of ball slide voids warranty.

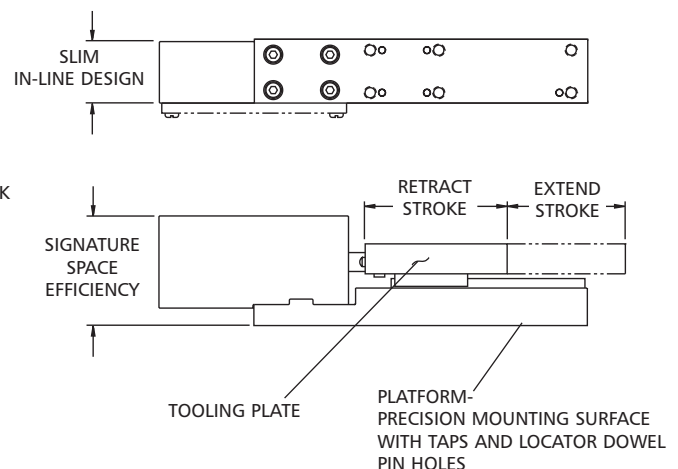

BSC1000 Series 8mm Bore

Part Number	Standard Stroke Length (mm)	A	B	C	D
BSC18x__	2,5 5 7,5 10 12,5 15	83	68,5	74	38
BSC18x__	17,5 20 22,5 25 27,5 30	113	83,5	89	53

All dimensions shown in millimeters unless otherwise noted.

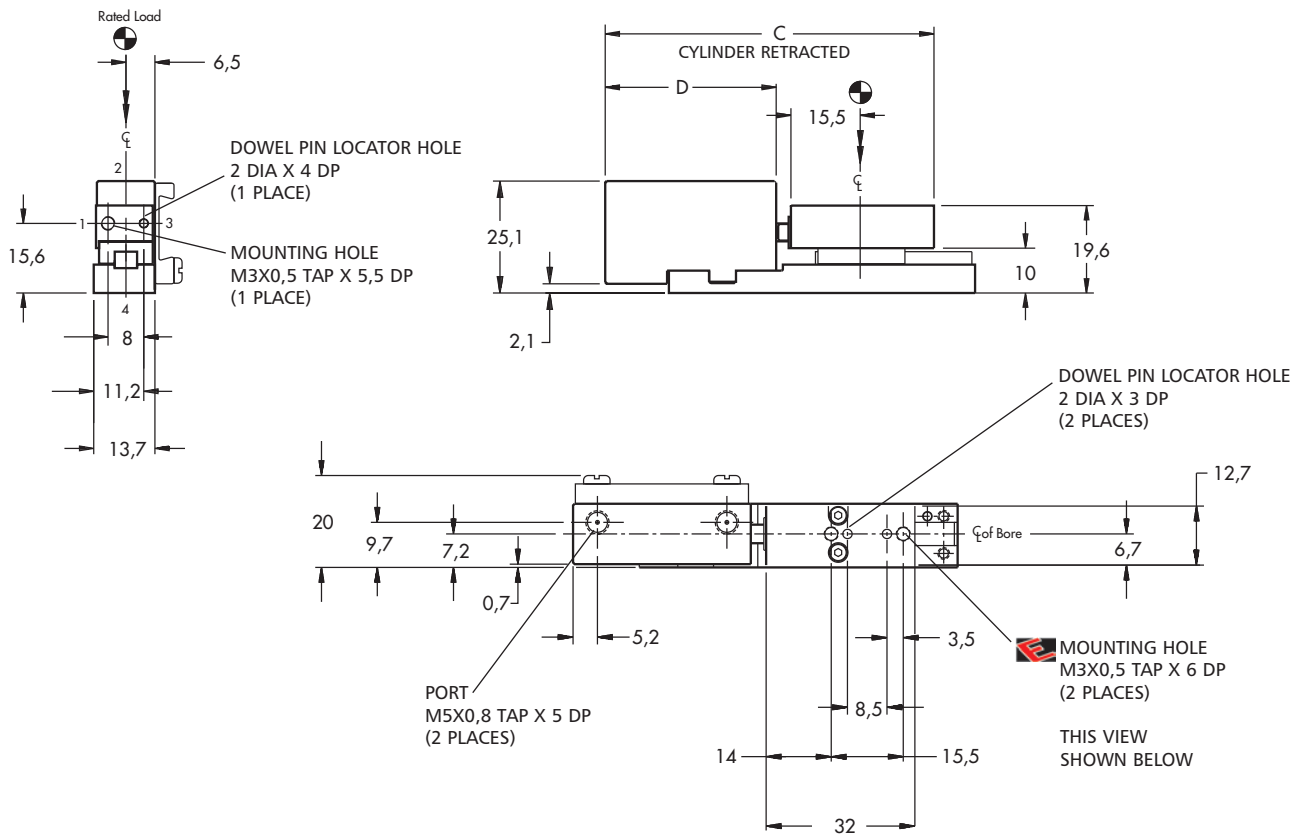
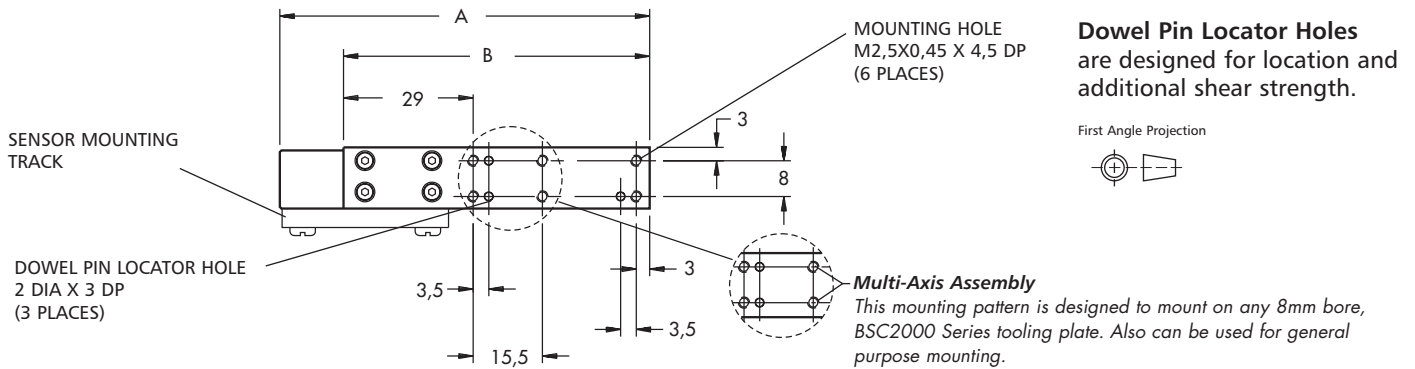

Easy Multi-Axis Assemblies

Pattern 1:
Adapts to a BSC2000 Series, Style 'B' cylinder, of the same bore size. Also can be used for general purpose mounting.

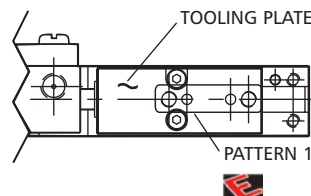

BSC1000 Series 12mm Bore

Part Number	Standard Stroke Length (mm)	A	B	C	D
BSC112x__	2,5 5 7,5 10 12,5 15	93	80,5	93,3	41
BSC112x__	17,5 20 22,5 25 27,5 30	123	95,5	108,3	56
BSC112x__	32,5 35 37,5 40 42,5 45 47,5 50	163	115,5	128,3	76

Dowel Pin Locator Holes are designed for location and additional shear strength.

First Angle Projection



All dimensions shown in millimeters unless otherwise noted.

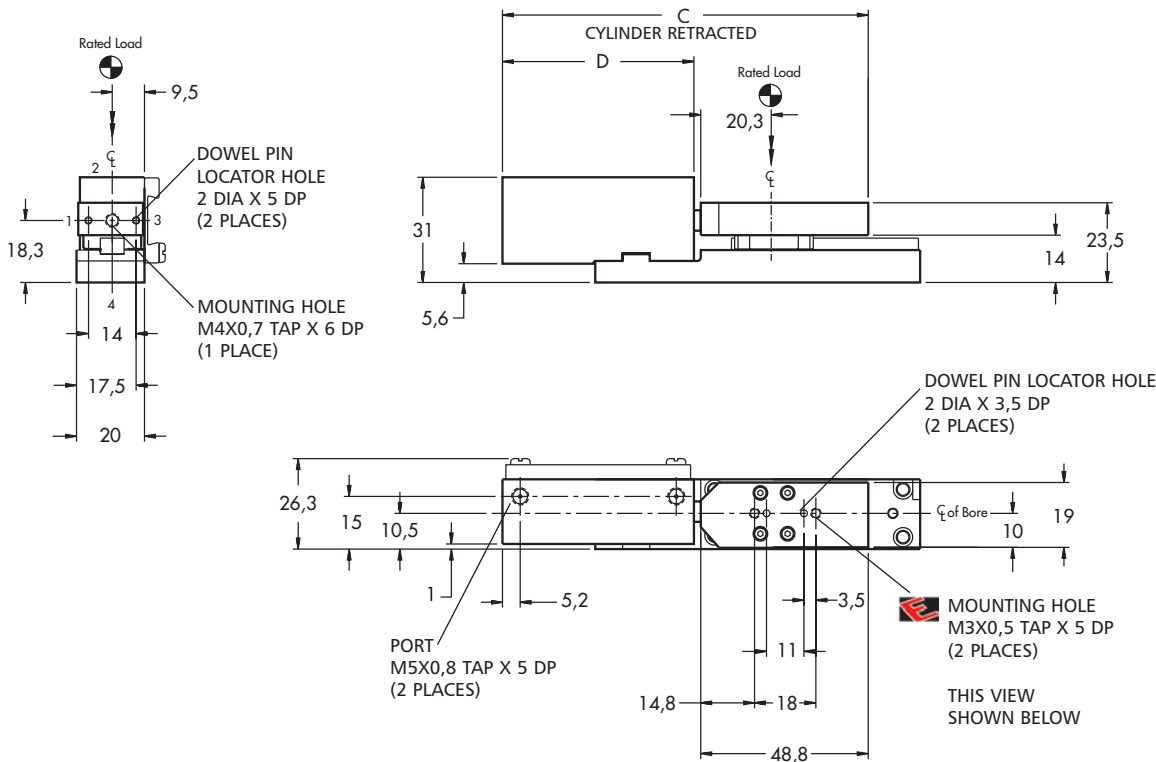
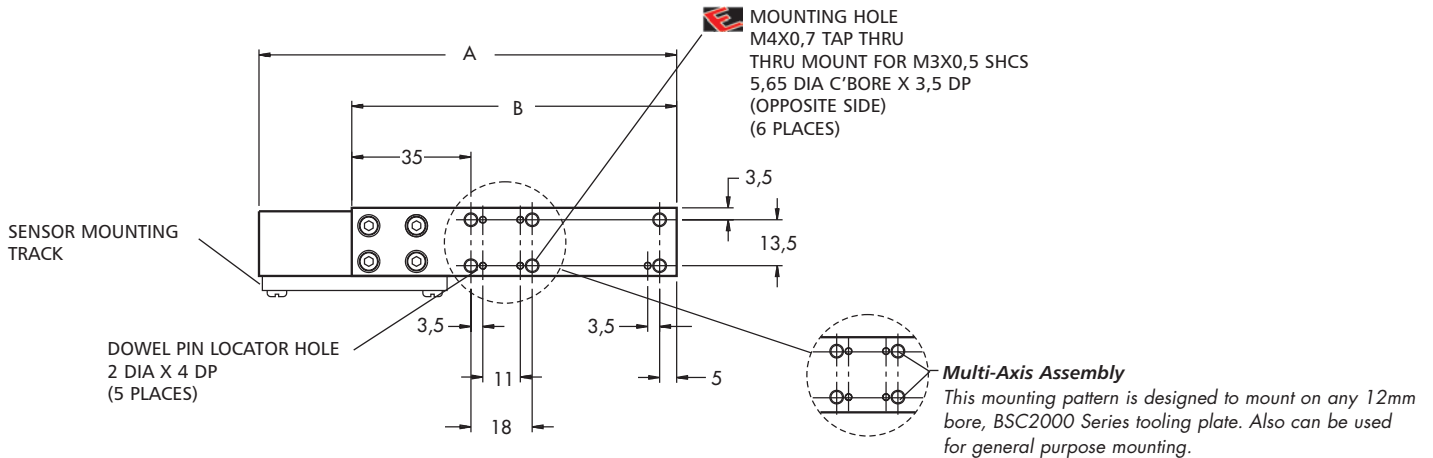

Easy Multi-Axis Assemblies

Pattern 1:
Adapts to a BSC2000 Series, Style 'B' cylinder, of the same bore size. Also can be used for general purpose mounting.

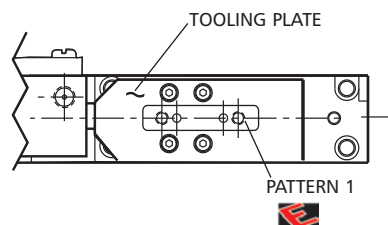

BSC1000 Series 20mm Bore

Part Number	Standard Stroke Length (mm)	A	B	C	D
BSC120x__	5 10 15	111	106	112	45
BSC120x__	20 25 30	141	121	127	60
BSC120x__	35 40 45 50	181	141	147	80
BSC120x__	55 60 65 70 75	231	166	172	105

Dowel Pin Locator Holes are designed for location and additional shear strength.

First Angle Projection



All dimensions shown in millimeters unless otherwise noted.

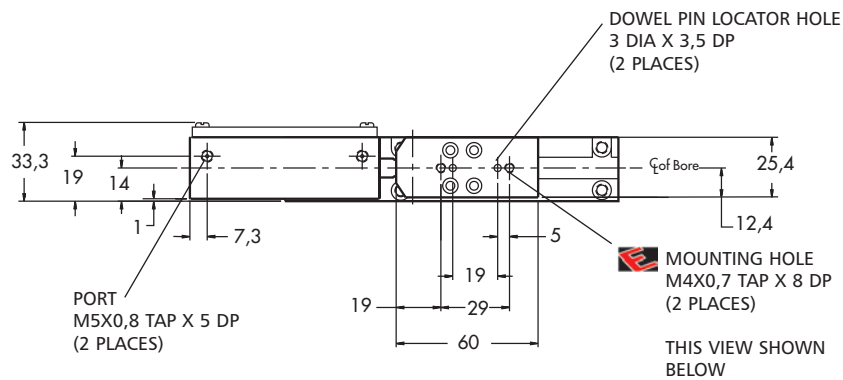
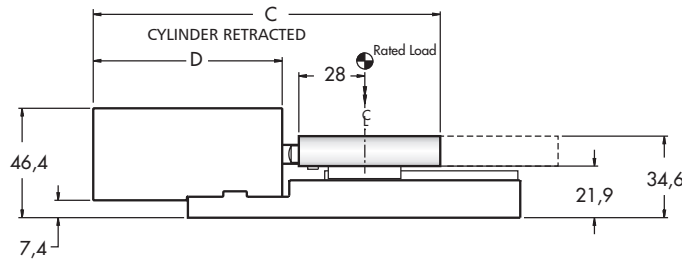
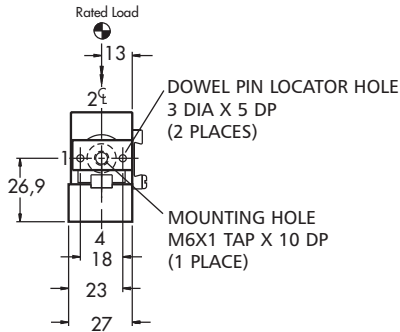
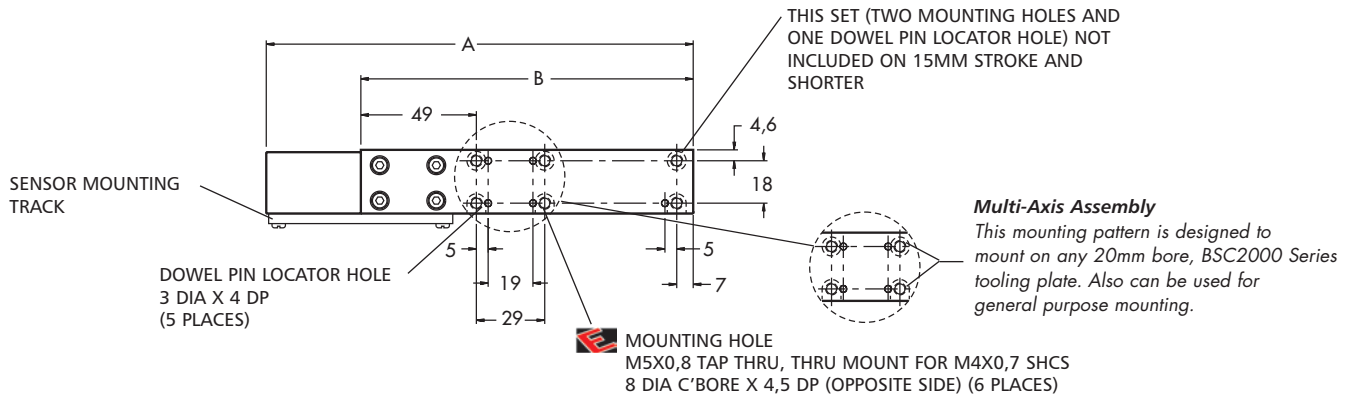

Easy Multi-Axis Assemblies

Pattern 1: Adapts to a BSC2000 Series, Style 'B' cylinder, of the same bore size. Also can be used for general purpose mounting.

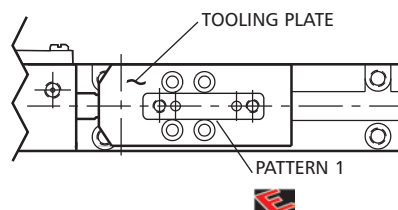

BSC1000 Series 25mm Bore

Part Number	Standard Stroke Length (mm)	A	B	C	D	E	F
BSC125X	5 10 15	120,13	112,0	123,5	50,13	4	2
BSC125X	20 25 30	150,13	127,0	138,5	65,13	6	3
BSC125X	35 40 45 50	190,13	147,0	158,5	85,13	6	3
BSC125X	55 60 65 70 75	240,13	172,0	183,5	110,13	6	3
BSC125X	80 85 90 95 100	290,13	197,0	208,5	135,1	6	3
BSC125X	105 110 115 120 125	340,13	222,0	233,5	160,13	6	3
BSC125X	130 135 140 145 150	390,13	247,0	258,5	185,13	6	3

All dimensions shown in millimeters unless otherwise noted.

Dowel Pin Locator Holes are designed for location and additional shear strength.

First Angle Projection



THIS SET (TWO MOUNTING HOLES AND ONE DOWEL PIN LOCATOR HOLE) NOT INCLUDED ON 15MM STROKE AND SHORTER

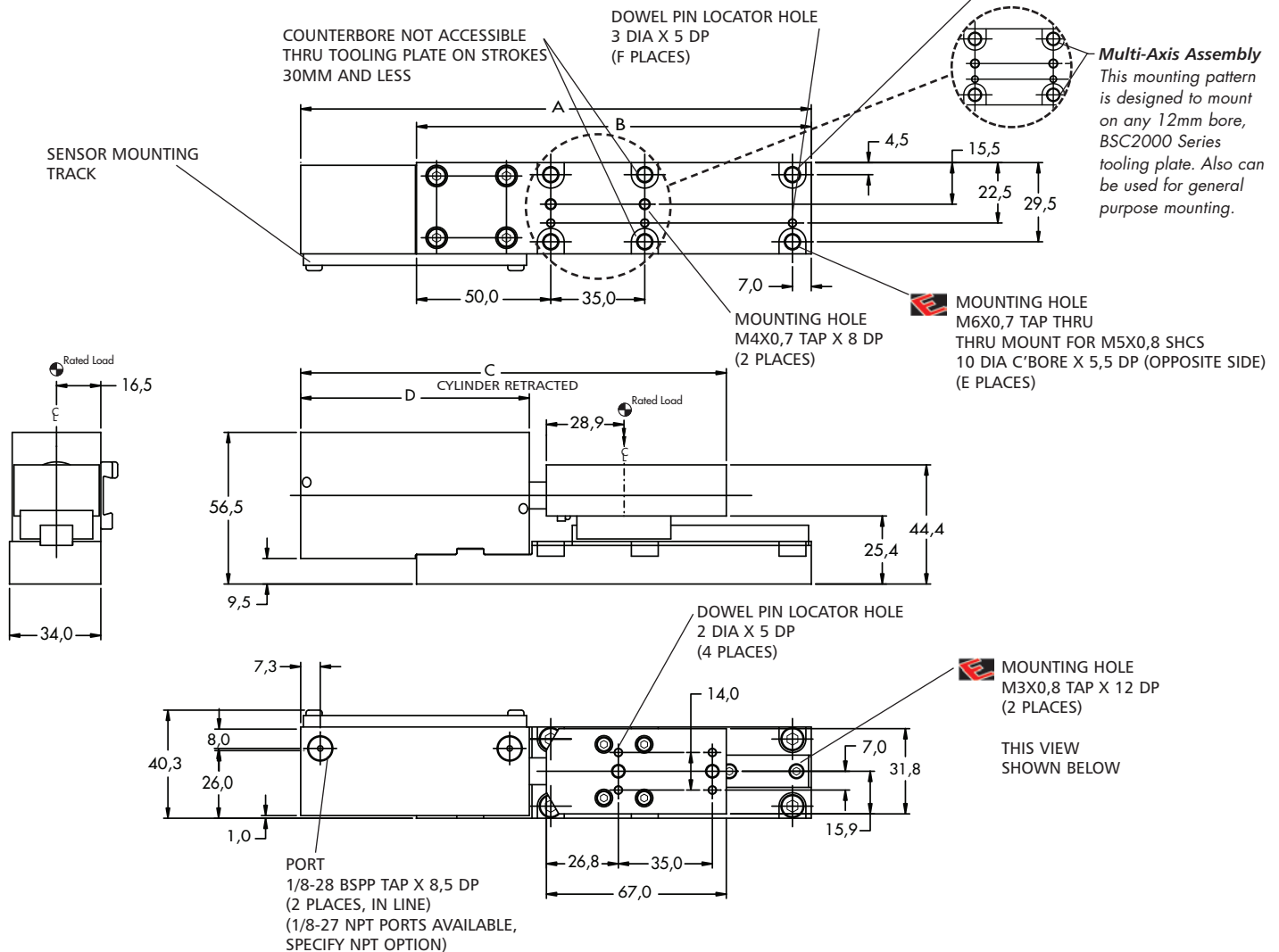



EXCLUSIVE
MOUNTING
PATTERN

Easy Multi-Axis Assemblies

Pattern 1:
Adapts to a BSC2000 Series, Style 'B' cylinder, of the same bore size. Also can be used for general purpose mounting.

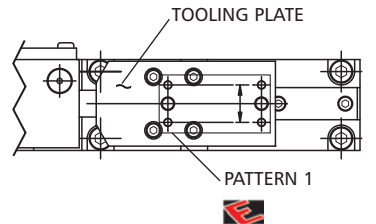

TOOLING PLATE

PATTERN 1

BSC1000 Series 40mm Bore

Part Number	Standard Stroke Length (mm)	A	B	C	D	E	F
BSC140X	5 10 15 20 25 30	165,6	149,5	166,7	71,13	4	3
BSC140X	35 40 45 50	205,6	169,5	186,7	91,13	6	4
BSC140X	55 60 65 70 75	255,6	194,5	211,7	116,13	6	4
BSC140X	80 85 90 95 100	305,6	219,5	236,7	141,13	6	4
BSC140X	105 110 115 120 125 130 135 140 145 150	405,6	269,5	286,7	191,13	6	4
BSC140X	155 160 165 170 175 180 185 190 195 200	505,6	319,5	336,7	241,13	6	4

All dimensions shown in millimeters unless otherwise noted.

Dowel Pin Locator Holes are designed for location and additional shear strength.

First Angle Projection

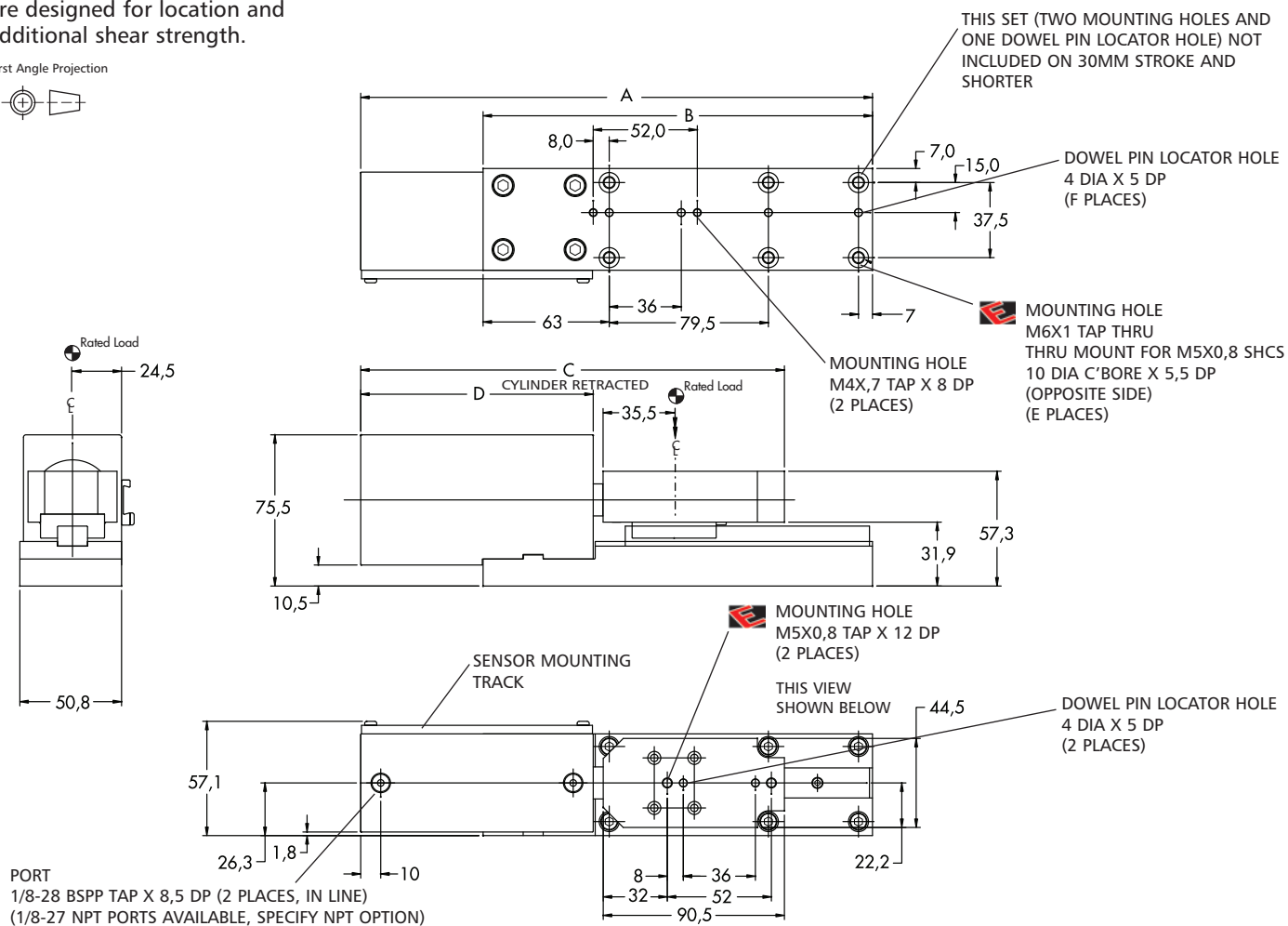



Easy Multi-Axis Assemblies

Pattern 1: Adapts to a BSC2000 Series, Style 'B' cylinder, of the same bore size. Also can be used for general purpose mounting.

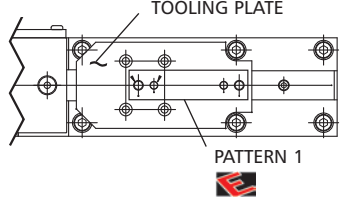

BSC1000 Series Load Ratings

Moment Loads

Bore Size	Stroke (mm)	Push Max. kgf	Pull Max. kgf	μ Coefficient of friction	C Basic Dynamic Load	Co Basic Static Load Rating	Ma kgf*m (lbf*in)	Da mm (in)	Mb kgf*m (lbf*in)	Mc kgf*m (lbf*in)	Dc mm (in)
8mm	2,5-30	4,25 (9.36)	3,2 (7.02)	See *Note below	32 (72)	60 (132)	0,06 (5)	18,8 (.74)	0,06 (5)	0,07 (6)	6,7 (.264)
12mm	2,5-50	9 (19.89)	6,9 (15.21)		90 (198)	140 (308)	0,1 (8.7)	23,5 (.93)	0,1 (8.7)	0,15 (13)	10 (.394)
20mm	5-75	47 (104)	39,5 (87)		150 (330)	230 (506)	0,2 (17)	35 (1.38)	0,2 (17)	0,3 (26)	13 (5.1)
25mm	5-150	75 (165)	63 (139)		270 (595)	410 (903)	0,5 (43.4)	35,3 (1.39)	0,5 (43.4)	1 (86.8)	15,9 (.63)
40 mm	5-200	192 (423)	161 (355)		450 (992)	670 (1477)	1 (86.8)	40,5 (1.6)	1 (86.8)	2 (173.6)	22,2 (.875)

*Note: Theoretical coefficient of friction of the bearing for loads $\geq .05C$ is $\leq .004$. Increased frictional resistance due to moment loads and the frictional resistance of the cylinder are additional to the bearing resistance.

Downward basic loads equal C and Co. For lateral loading, dynamic load rating equals 0,82 C and static load rating equals 0,76 Co. For upward loading, dynamic load rating equals 0,78 C and static load rating equals 0,70 Co.

The slide does not increase the push or pull capabilities of the pneumatic system. Flow controls are recommended to improve the life of the overall system if high loads and/or speeds are expected.

Basic dynamic load rating of the slide is defined as a load whose direction and magnitude are constant and under which 90% of the slides traveled 50×10^3 meters (1.9 million inches) without suffering from material damage due to rolling contact fatigue. Life is increased when moment loads are observed.

Basic static load rating of the slide is defined as the static load which gives a prescribed contact stress at the center of contact area between the rolling element and the raceway which are receiving the maximum load.

Basic loads and moment arm lengths are assumed centered on slide carriage. Moment and load directions are as illustrated:

La, Lb and Lc are distances from frame to loading point.

Formulas for allowable static loads in kg:

$$Fa = \frac{Ma(1000)}{La - Da}$$

$$Fb = \frac{Mb(1000)}{Lb - Da}$$

$$Fc = \frac{Mc(1000)}{Lc + Dc}$$

$$Fc = \frac{Mc(1000)}{Lc + Dc}$$

$$Fc = \frac{Mc(1000)}{Lc + Dc}$$

$$Fc = \frac{Mc(1000)}{Lc + Dc}$$

For example: 20mm x 30mm Stroke
Part No.: BSC120x30

$$Da = 35\text{mm} \quad Dc = 13\text{mm}$$

$$\text{If } La = 50\text{mm}, Lb = 50\text{mm} \text{ or } Lc = 0$$

$$\text{Then: } Fa = \frac{.2(1000)}{50-35} = 13 \text{ kgf} = 29 \text{ lbf}$$

$$Fb = \frac{.2(1000)}{50-35} = 13 \text{ kgf} = 29 \text{ lbf}$$

$$Fc = \frac{.3(1000)}{0+13} = 23 \text{ kgf} = 51 \text{ lbf}$$

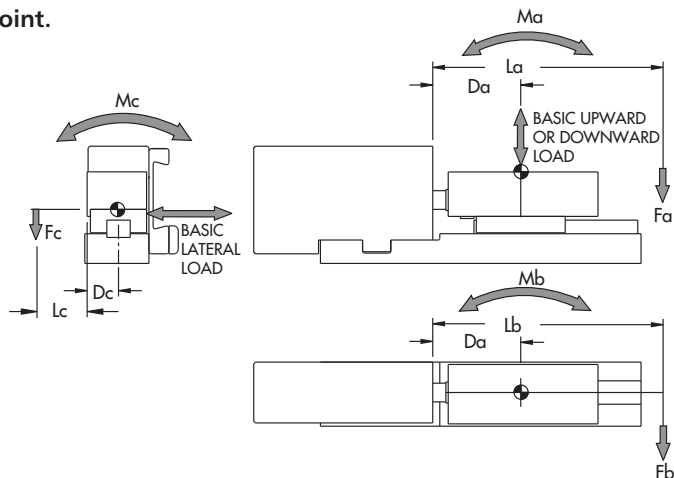

CAUTION!

Forces resulting from inertia must be considered in your application.

Use equipment within specifications.

Reference:

$$1 \text{ kgf} = 9,807 \text{ N} = 2.2046 \text{ lbf}$$

$$1 \text{ mm} = .03937 \text{ in}$$

$$1 \text{ kgf*m} = 9,807 \text{ N*m}$$

$$1 \text{ lbf*in} = 0,0115 \text{ kgf*m}$$

$$1 \text{ kgf*m} = 86.8 \text{ lbf*in}$$

BSC2000 Series

Pneumatic Cylinder

8 mm, 12mm, 20mm, 25mm and 40mm Bore

General Information

- Recirculating ball type slide, factory matched
- Side or rear porting
- Sensor ready
- Three mounting styles
- Multi-axis applications - no transition plates required
- Stroke lengths (mm):
 - > 8mm bore: 2,5-30
 - > 12mm bore: 2,5-50
 - > 20mm bore: 5-75
 - > 25mm bore: 5-150
 - > 40mm bore: 5-200
- Multi-position and Multi-piston cylinders - See Accessories section
- Modifications welcome — Larger bore sizes, longer stroke lengths, etc. Consult factory.



Available in 15 models

- 8mm Bore
 - End mount, Side mount, Thin mount
- 12mm Bore
 - End mount, Side mount, Thin mount
- 20mm Bore
 - End mount, Side mount, Thin mount
- 25mm Bore
 - End mount, Side mount, Thin mount
- 40mm Bore
 - End mount, Side mount, Thin mount

Note: Multi-position and Multi-piston design shown in Accessories section

Part number shown:
BSC2B20x25

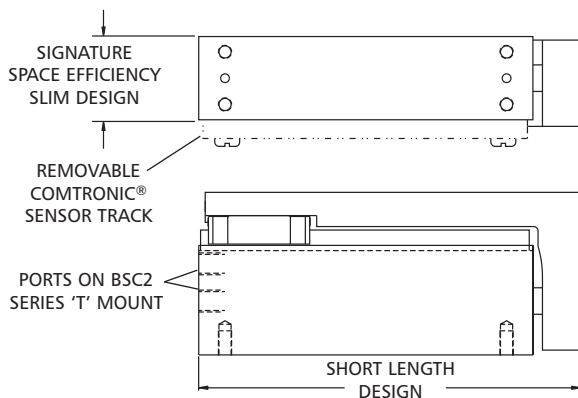
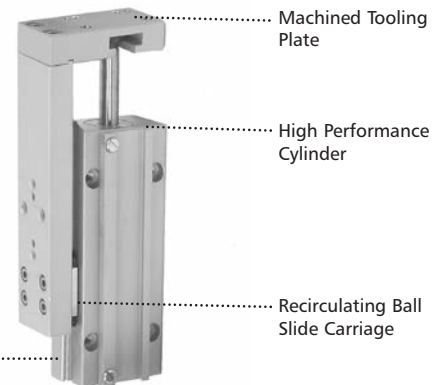

WARNING!

Pressurizing actuated equipment creates pinch points. Prevent operator access to moving equipment and work pieces.

CAUTION!

Mounting hardware must not interfere with ball slide function. Disassembly of ball slide voids warranty.

Three Mounting Versions — Available on all Bore Sizes

Rear View Shown

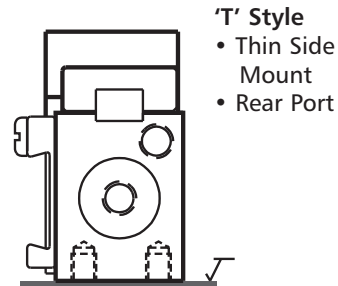
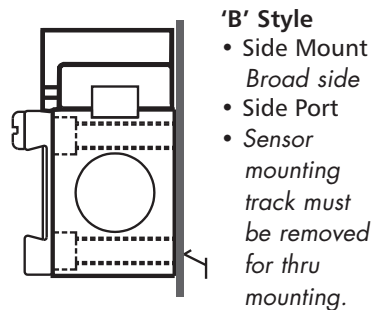
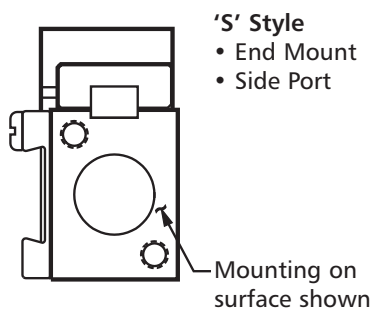

Part Number	Standard Stroke Length (mm)	A	B	C
BSC2S8x__	2,5 5 7,5 10 12,5 15	49	47	38
BSC2S8x__	17,5 20 22,5 25 27,5 30	64	62	53

All dimensions shown in millimeters unless otherwise noted.

Dowel Pin Locator Holes are designed for location and additional shear strength.

First Angle Projection

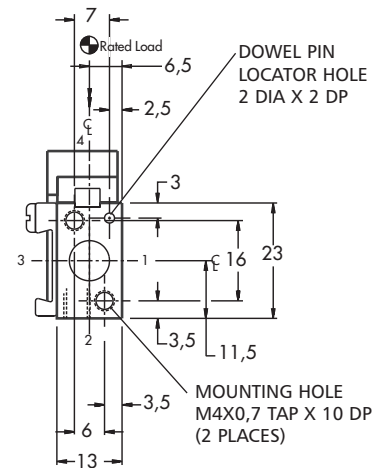
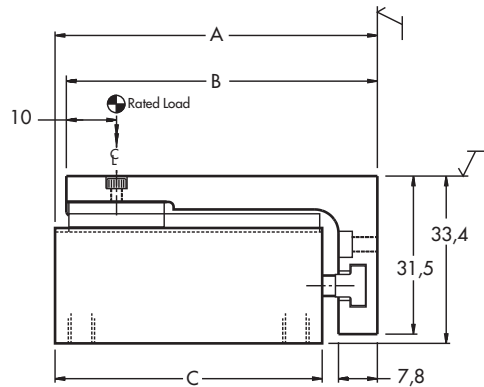
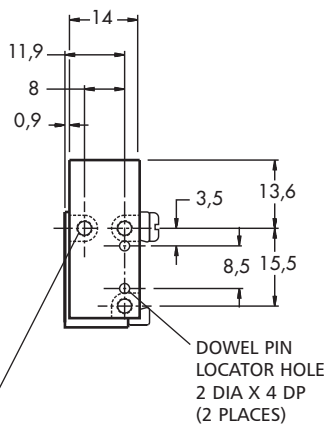
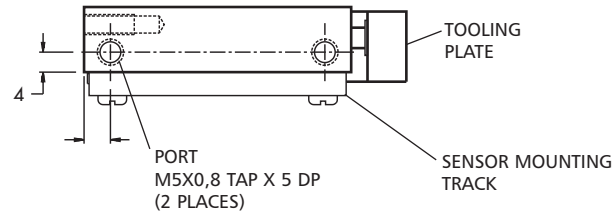

Use discretion when mounting this in a horizontal application

E MOUNTING HOLE M3X0,5 TAP THRU THRU MOUNT FOR M2,5 SHCS 5,2 DIA C'BORE X 2,75 DP (OPPOSITE SIDE) (3 PLACES)

THIS VIEW SHOWN BELOW

E MOUNTING HOLE M3X0,5 TAP X 5 DP (MAX) (2 PLACES)

THIS VIEW SHOWN BELOW

DOWEL PIN LOCATOR HOLE 2 DIA X 4 DP (2 PLACES)

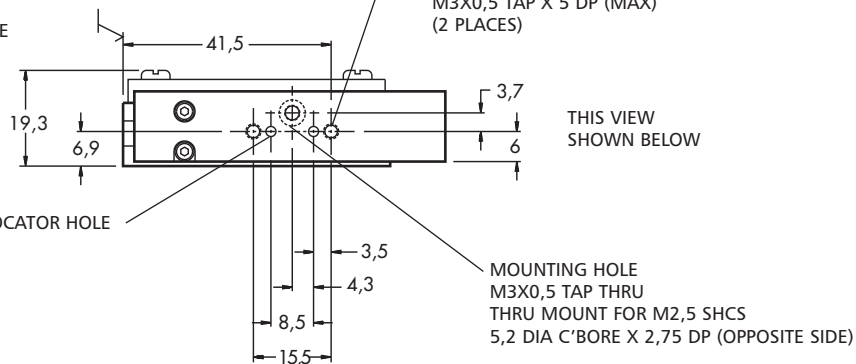

Easy Multi-Axis Assemblies

Both surfaces on the plate have mounting patterns:

Pattern 1:

Adapts to a BSC1000 Series mounting platform - or - a BSC2000 Series, Style 'B' cylinder, both of the same bore size. Also can be used for general purpose mounting.

Pattern 2:

Adapts to a BSC2000 Series, Style 'B' cylinder of the same bore size. Also can be used for

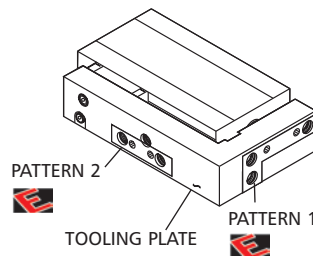

Part Number	Standard Stroke Length (mm)	A	B	C
BSC2B8x__	2,5 5 7,5 10 12,5 15	49	47	38
BSC2B8x__	17,5 20 22,5 25 27,5 30	64	62	53

Dowel Pin Locator Holes are designed for location and additional shear strength.

First Angle Projection



All dimensions shown in millimeters unless otherwise noted.

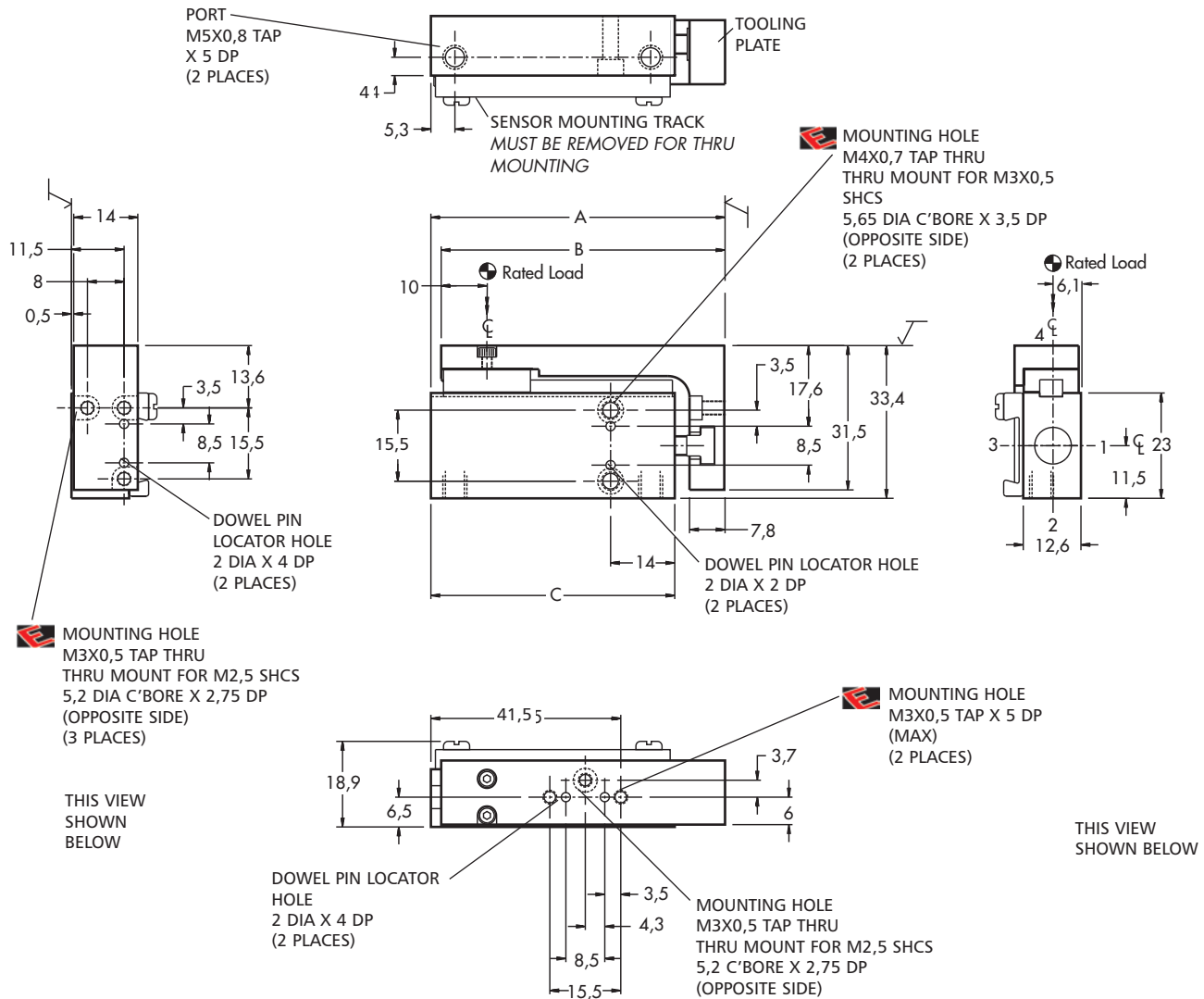

Easy Multi-Axis Assemblies

Both surfaces on the plate have mounting patterns:

Pattern 1:

Adapts to a BSC1000 Series mounting platform - or - a BSC2000 Series, Style 'B' cylinder, both of the same bore size. Also can be used for general purpose mounting.

Pattern 2:

Adapts to a BSC2000 Series, Style 'B' cylinder of the same bore size. Also can be used for

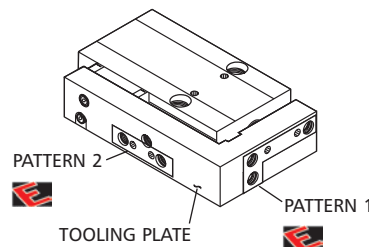

Part Number	Standard Stroke Length (mm)	A	B	C
BSC2T8x__	2,5 5 7,5 10 12,5 15	49	47	38
BSC2T8x__	17,5 20 22,5 25 27,5 30	64	62	53

Dowel Pin Locator Holes are designed for location and additional shear strength.

First Angle Projection



All dimensions shown in millimeters unless otherwise noted.

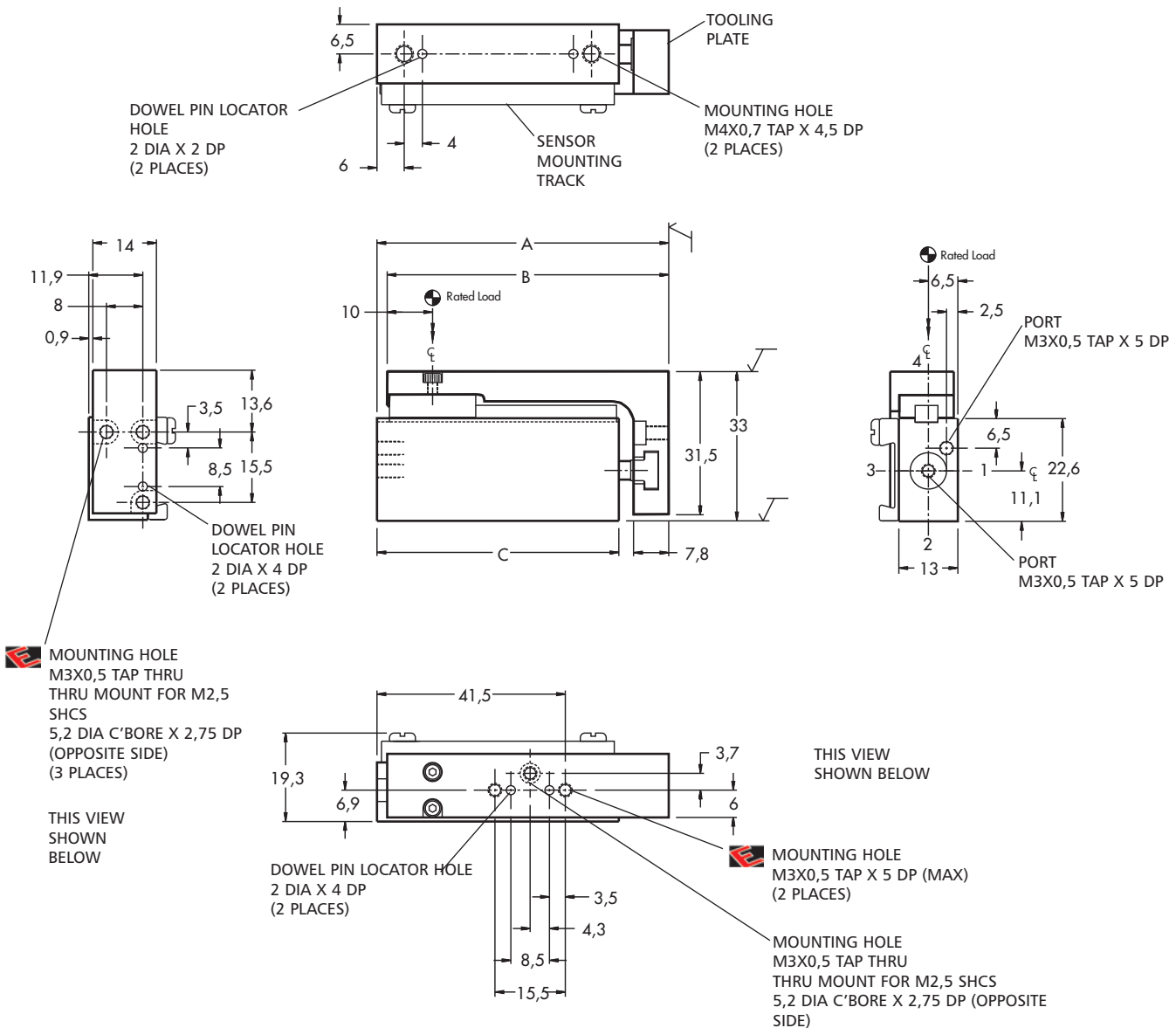

Easy Multi-Axis Assemblies

Both surfaces on the plate have mounting patterns:

Pattern 1:

Adapts to a BSC1000 Series mounting platform - or - a BSC2000 Series, Style 'B' cylinder, both of the same bore size. Also can be used for general purpose mounting.

Pattern 2:

Adapts to a BSC2000 Series, Style 'B' cylinder of the same bore size. Also can be used for

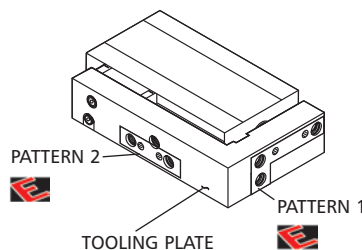

Part Number	Standard Stroke Length (mm)	A	B	C
BSC2S12x	2,5 5 7,5 10 12,5 15	52	50,5	41
BSC2S12x	17,5 20 22,5 25 27,5 30	67	65,5	56
BSC2S12x	32,5 35 37,5 40 42,5 45 47,5 50	87	85,5	76

All dimensions shown in millimeters unless otherwise noted.

Dowel Pin Locator Holes are designed for location and additional shear strength.

First Angle Projection

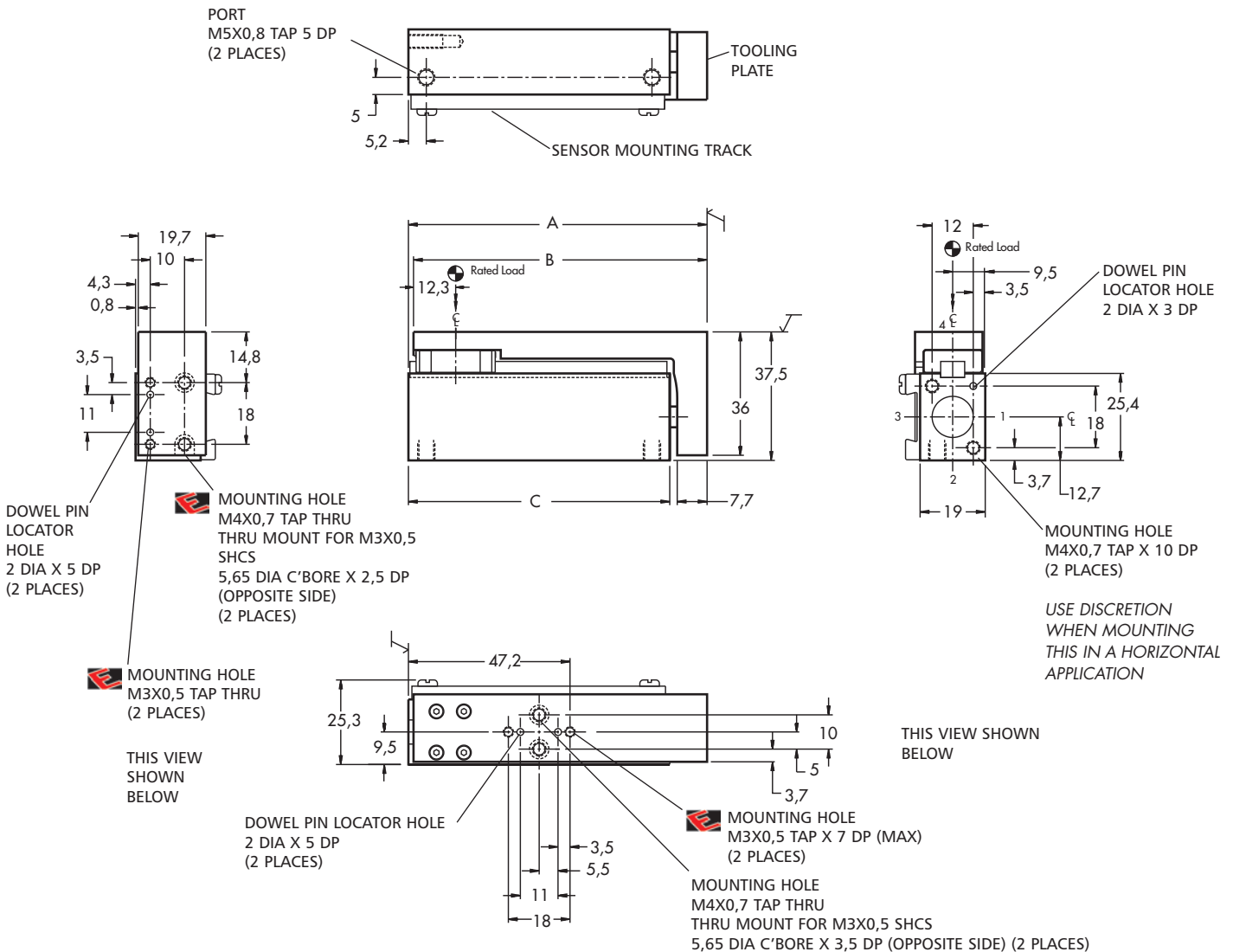

Easy Multi-Axis Assemblies

Both surfaces on the plate have mounting patterns:

Pattern 1:

Adapts to a BSC1000 Series mounting platform - or - a BSC2000 Series, Style 'B' cylinder, both of the same bore size. Also can be used for general purpose mounting.

Pattern 2:

Adapts to a BSC2000 Series, Style 'B' cylinder of the same bore size. Also can be used for

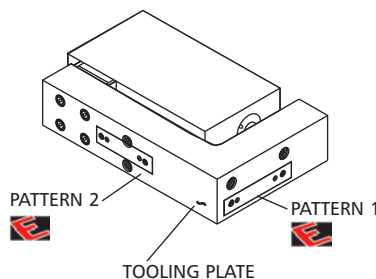

Part Number	Standard Stroke Length (mm)	A	B	C	D	E
BSC2B12x	2,5 5 7,5 10 12,5 15	52	50,5	-	41	2
BSC2B12x	17,5 20 22,5 25 27,5 30	67	65,5	16	56	4
BSC2B12x	32,5 35 37,5 40 42,5 45 47,5 50	87	85,5	16	76	4

Dowel Pin Locator Holes are designed for location and additional shear strength.

First Angle Projection



All dimensions shown in millimeters unless otherwise noted.

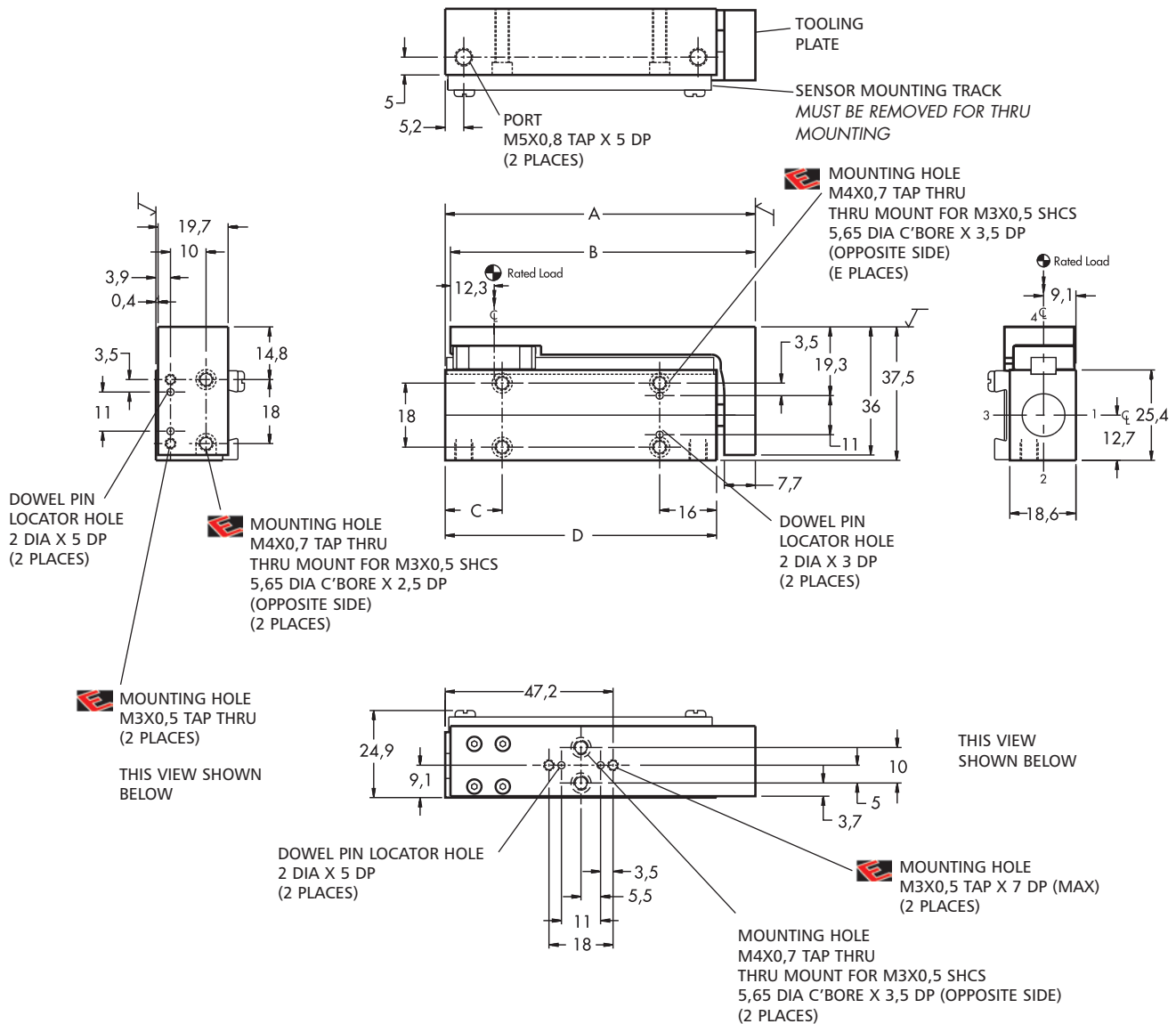

Easy Multi-Axis Assemblies

Both surfaces on the plate have mounting patterns:

Pattern 1:

Adapts to a BSC1000 Series mounting platform - or - a BSC2000 Series, Style 'B' cylinder, both of the same bore size. Also can be used for general purpose mounting.

Pattern 2:

Adapts to a BSC2000 Series, Style 'B' cylinder of the same bore size. Also can be used for

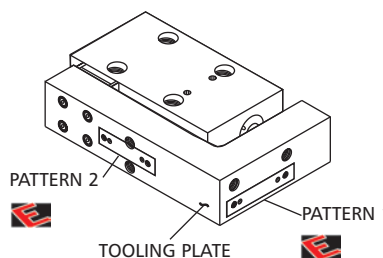

Part Number	Standard Stroke Length (mm)	A	B	C
BSC2T12x	2,5 5 7,5 10 12,5 15	52	50,5	41
BSC2T12x	17,5 20 22,5 25 27,5 30	67	65,5	56
BSC2T12x	32,5 35 37,5 40 42,5 45 47,5 50	87	85,5	76

All dimensions shown in millimeters unless otherwise noted.

Dowel Pin Locator Holes are designed for location and additional shear strength.

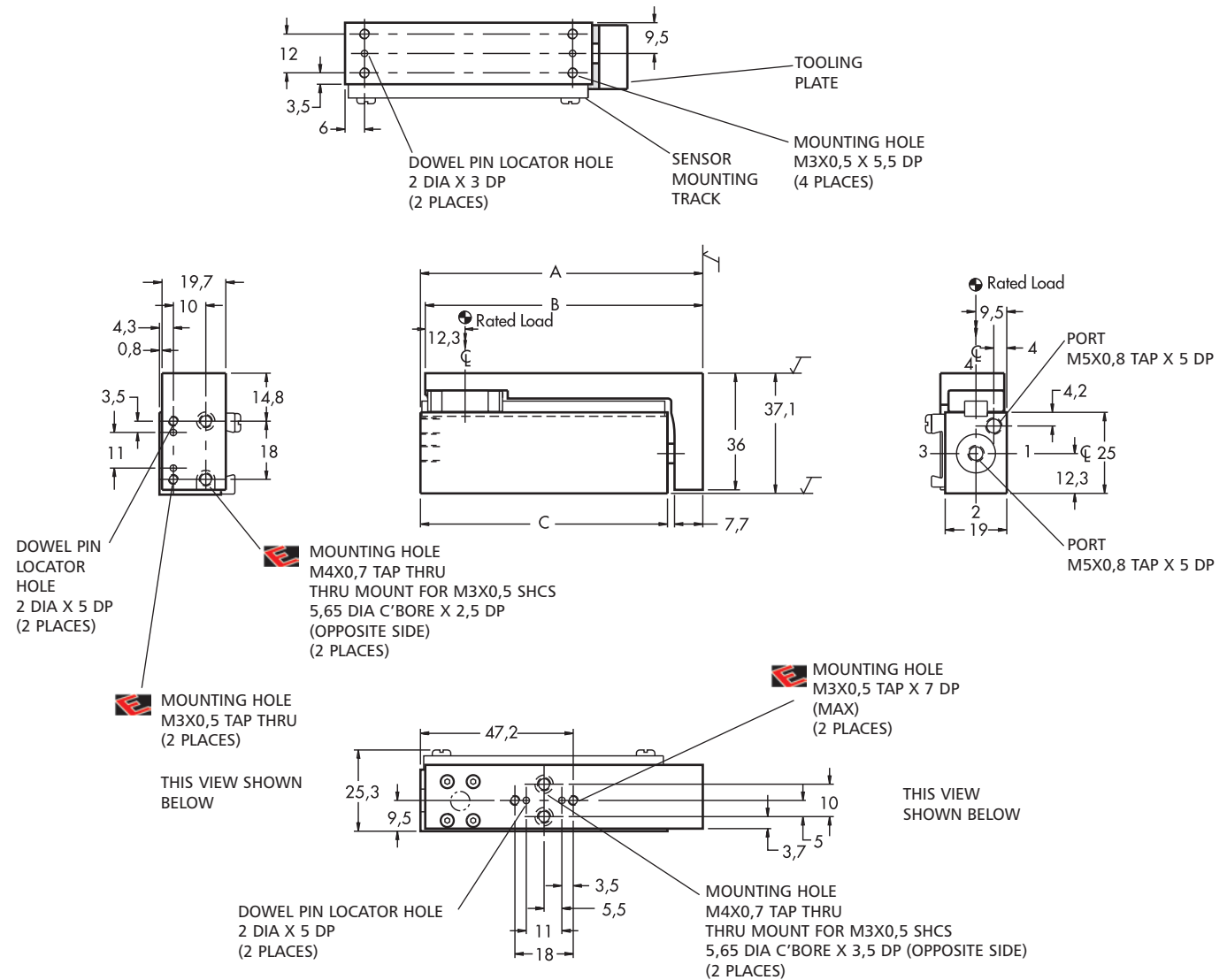
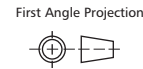



Easy Multi-Axis Assemblies

Both surfaces on the plate have mounting patterns:

Pattern 1:
Adapts to a BSC1000 Series mounting platform - or - a BSC2000 Series, Style 'B' cylinder, both of the same bore size. Also can be used for general purpose mounting.

Pattern 2:
Adapts to a BSC2000 Series, Style 'B' cylinder of the same bore size. Also can be used for

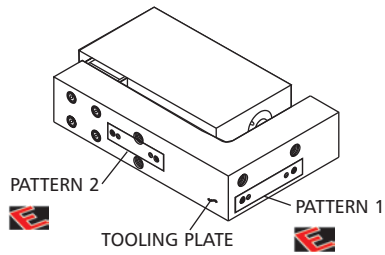

Part Number	Standard Stroke Length (mm)	A	B	C
BSC2S20x	5 10 15	64,5	62,5	45
BSC2S20x	20 25 30	79,5	77,5	60
BSC2S20x	35 40 45 50	99,5	97,5	80
BSC2S20x	55 60 65 70 75	124,5	122,5	105

Dowel Pin Locator Holes are designed for location and additional shear strength.

First Angle Projection



All dimensions shown in millimeters unless otherwise noted.

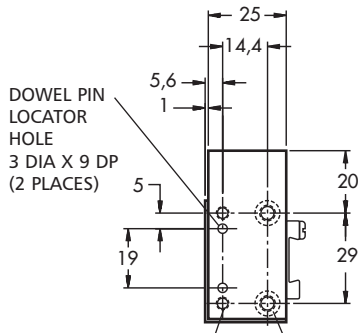
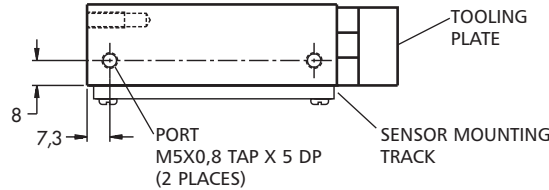

MOUNTING HOLE M4X0,7 TAP THRU (2 PLACES)

THIS VIEW SHOWN BELOW

MOUNTING HOLE M5X0,8 TAP THRU THRU MOUNT FOR M4X0,7 SHCS 8 DIA C'BORE X 4,5 DP (OPPOSITE SIDE) (2 PLACES)

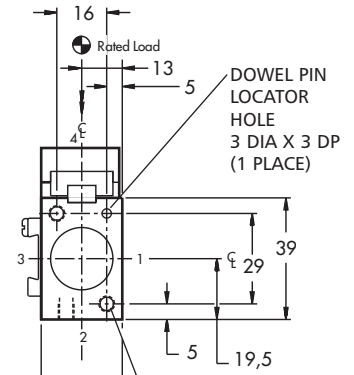
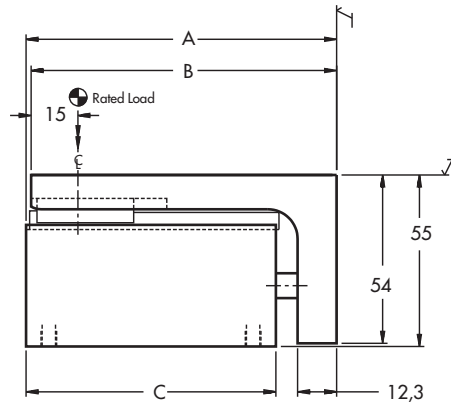

USE DISCRETION WHEN MOUNTING THIS IN A HORIZONTAL APPLICATION

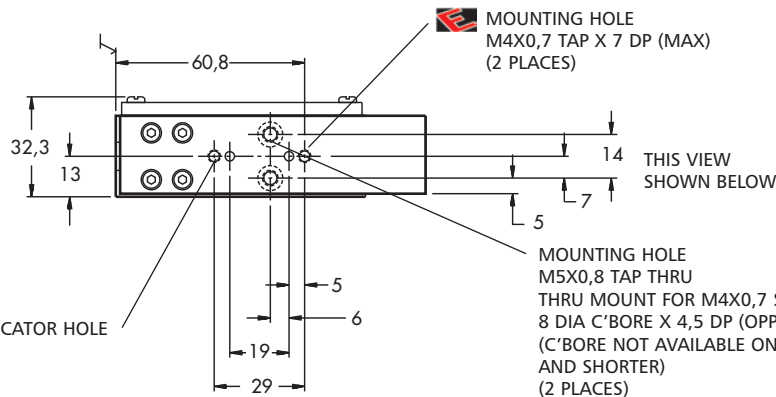

Easy Multi-Axis Assemblies

Both surfaces on the plate have mounting patterns:

Pattern 1:

Adapts to a BSC1000 Series mounting platform - or - a BSC2000 Series, Style 'B' cylinder, both of the same bore size. Also can be used for general purpose mounting.

Pattern 2:

Adapts to a BSC2000 Series, Style 'B' cylinder of the same bore size. Also can be used for

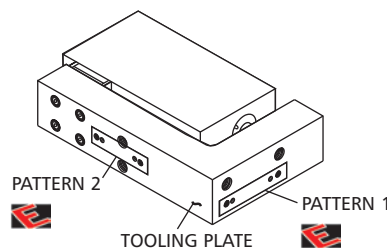

Part Number	Standard Stroke Length (mm)	A	B	C	D	E
BSC2B20x	5 10 15	64,5	62,5	-	45	2
BSC2B20x	20 25 30	79,5	77,5	19	60	4
BSC2B20x	35 40 45 50	99,5	97,5	19	80	4
BSC2B20x	55 60 65 70 75	124,5	122,5	19	105	4

All dimensions shown in millimeters unless otherwise noted.

Dowel Pin Locator Holes are designed for location and additional shear strength.

First Angle Projection

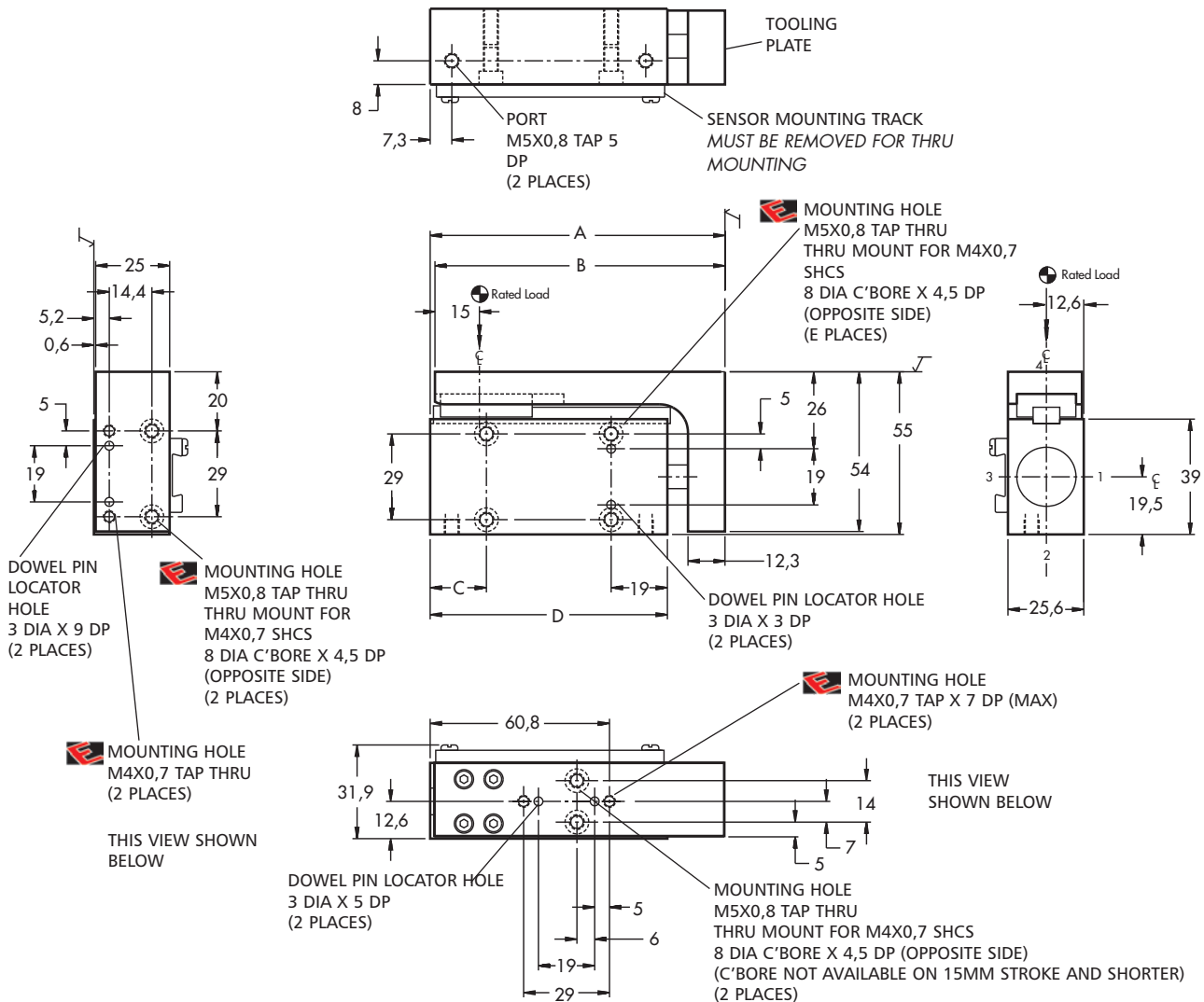

Easy Multi-Axis Assemblies

Both surfaces on the plate have mounting patterns:

Pattern 1:

Adapts to a BSC1000 Series mounting platform - or - a BSC2000 Series, Style 'B' cylinder, both of the same bore size. Also can be used for general purpose mounting.

Pattern 2:

Adapts to a BSC2000 Series, Style 'B' cylinder of the same bore size. Also can be used for

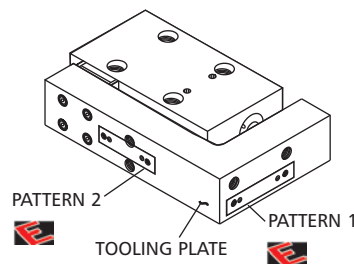

Part Number	Standard Stroke Length (mm)	A	B	C
BSC2T20x	5 10 15	64,5	62,5	45
BSC2T20x	20 25 30	79,5	77,5	60
BSC2T20x	35 40 45 50	99,5	97,5	80
BSC2T20x	55 60 65 70 75	124,5	122,5	105

Dowel Pin Locator Holes are designed for location and additional shear strength.

First Angle Projection



All dimensions shown in millimeters unless otherwise noted.

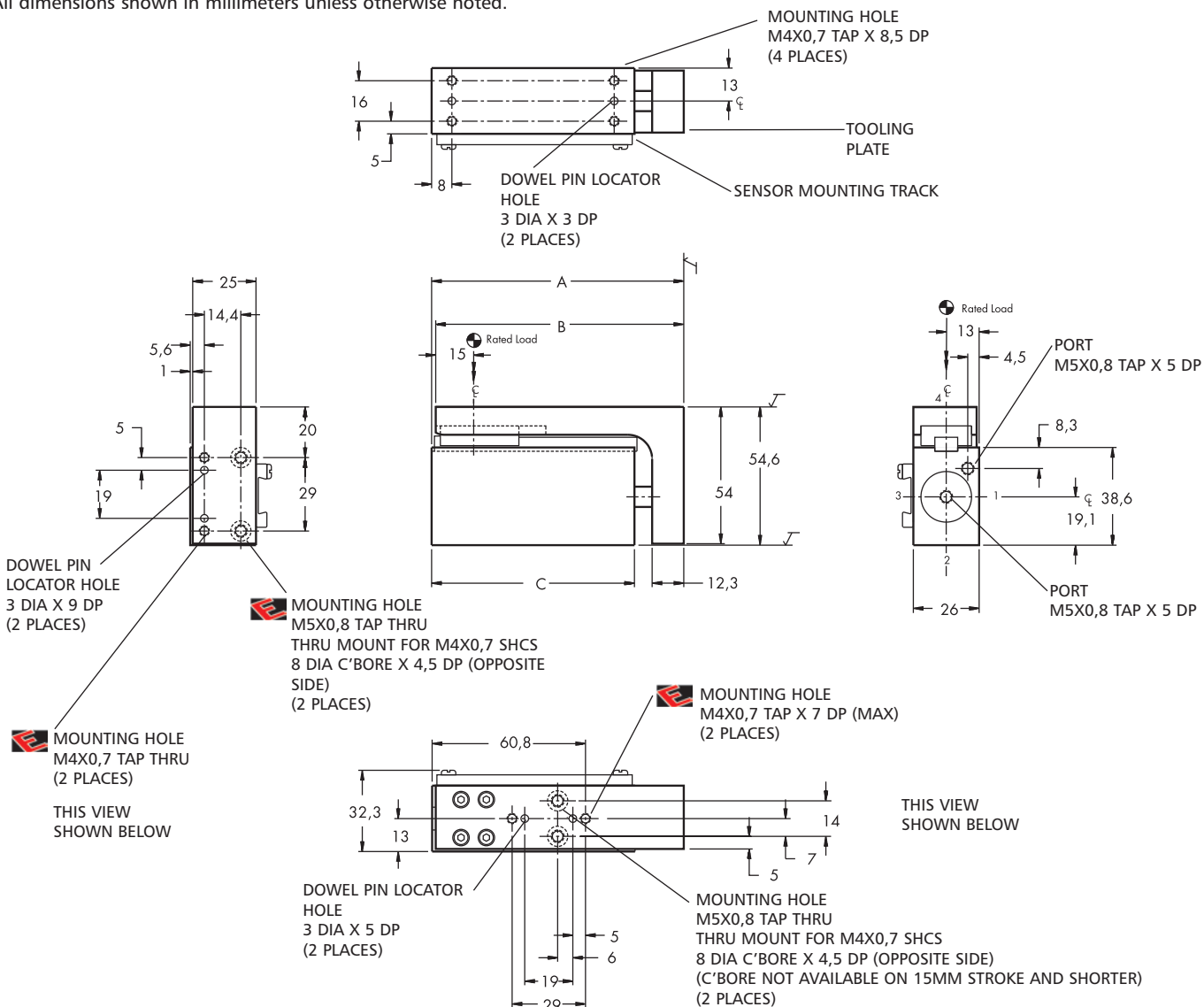

Easy Multi-Axis Assemblies

Both surfaces on the plate have mounting patterns:

Pattern 1:

Adapts to a BSC1000 Series mounting platform - or - a BSC2000 Series, Style 'B' cylinder, both of the same bore size. Also can be used for general purpose mounting.

Pattern 2:

Adapts to a BSC2000 Series, Style 'B' cylinder of the same bore size. Also can be used for

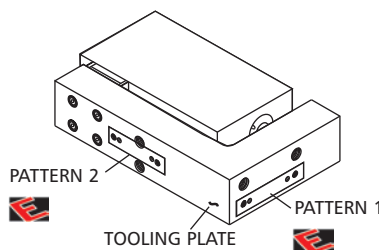

Part Number	Standard Stroke Length (mm)	A	B	C	D
BSC2S25X__	5 10 15	69,2	68,0	50,13	51,7
BSC2S25X__	20 25 30	84,2	83,0	65,13	66,7
BSC2S25X__	35 40 45 50	104,2	103,0	85,13	66,7
BSC2S25X__	55 60 65 70 75	129,2	128,0	110,13	66,7
BSC2S25X__	80 85 90 95 100	154,2	153,0	135,1	66,7
BSC2S25X__	105 110 115 120 125	179,2	178,0	160,13	66,7
BSC2S25X__	130 135 140 145 150	204,2	203,0	185,13	66,7

All dimensions shown in millimeters unless otherwise noted.

Dowel Pin Locator Holes are designed for location and additional shear strength.

First Angle Projection

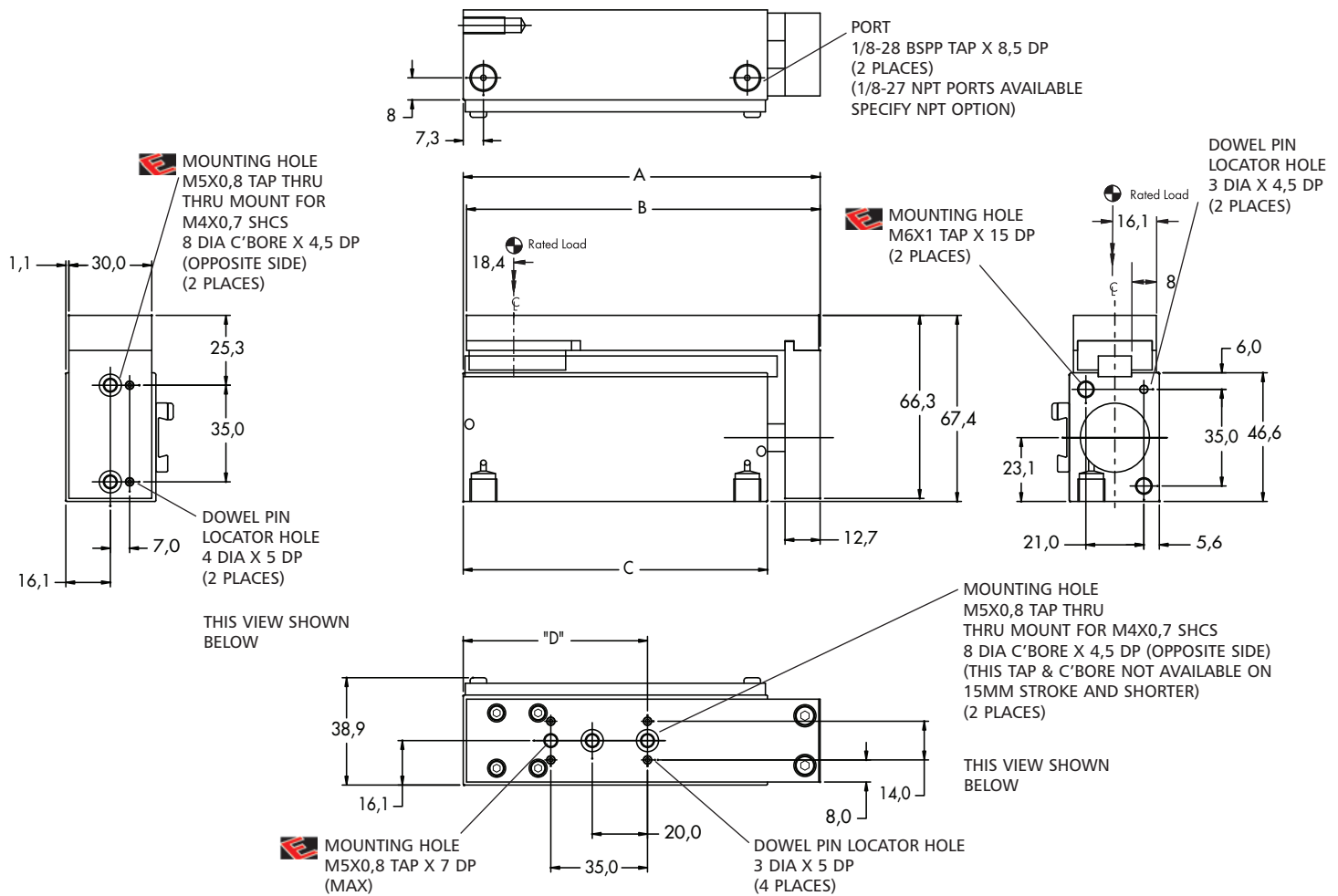

Easy Multi-Axis Assemblies

Both surfaces on the plate have mounting patterns:

Pattern 1:

Adapts to a BSC1000 Series mounting platform - or - a BSC2000 Series, Style 'B' cylinder, both of the same bore size. Also can be used for general purpose mounting.

Pattern 2:

Adapts to a BSC2000 Series, Style 'B' cylinder of the same bore size. Also can be used for

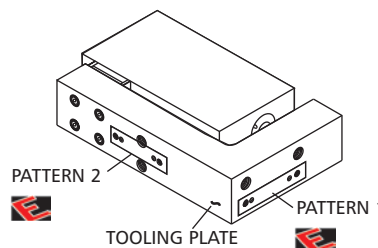



Part Number	Standard Stroke Length (mm)	A	B	C	D	E	F
BSC2B25X	5 10 15	69,2	68,0	---	50,13	2	51,7
BSC2B25X	20 25 30	84,2	83,0	19,0	65,13	4	66,7
BSC2B25X	35 40 45 50	104,2	103,0	19,0	85,13	4	66,7
BSC2B25X	55 60 65 70 75	129,2	128,0	19,0	110,13	4	66,7
BSC2B25X	80 85 90 95 100	154,2	153,0	19,0	135,13	4	66,7
BSC2B25X	105 110 115 120 125	179,2	178,0	19,0	160,13	4	66,7
BSC2B25X	130 135 140 145 150	204,2	203,0	19,0	185,13	4	66,7

All dimensions shown in millimeters unless otherwise noted.

Dowel Pin Locator Holes are designed for location and additional shear strength.

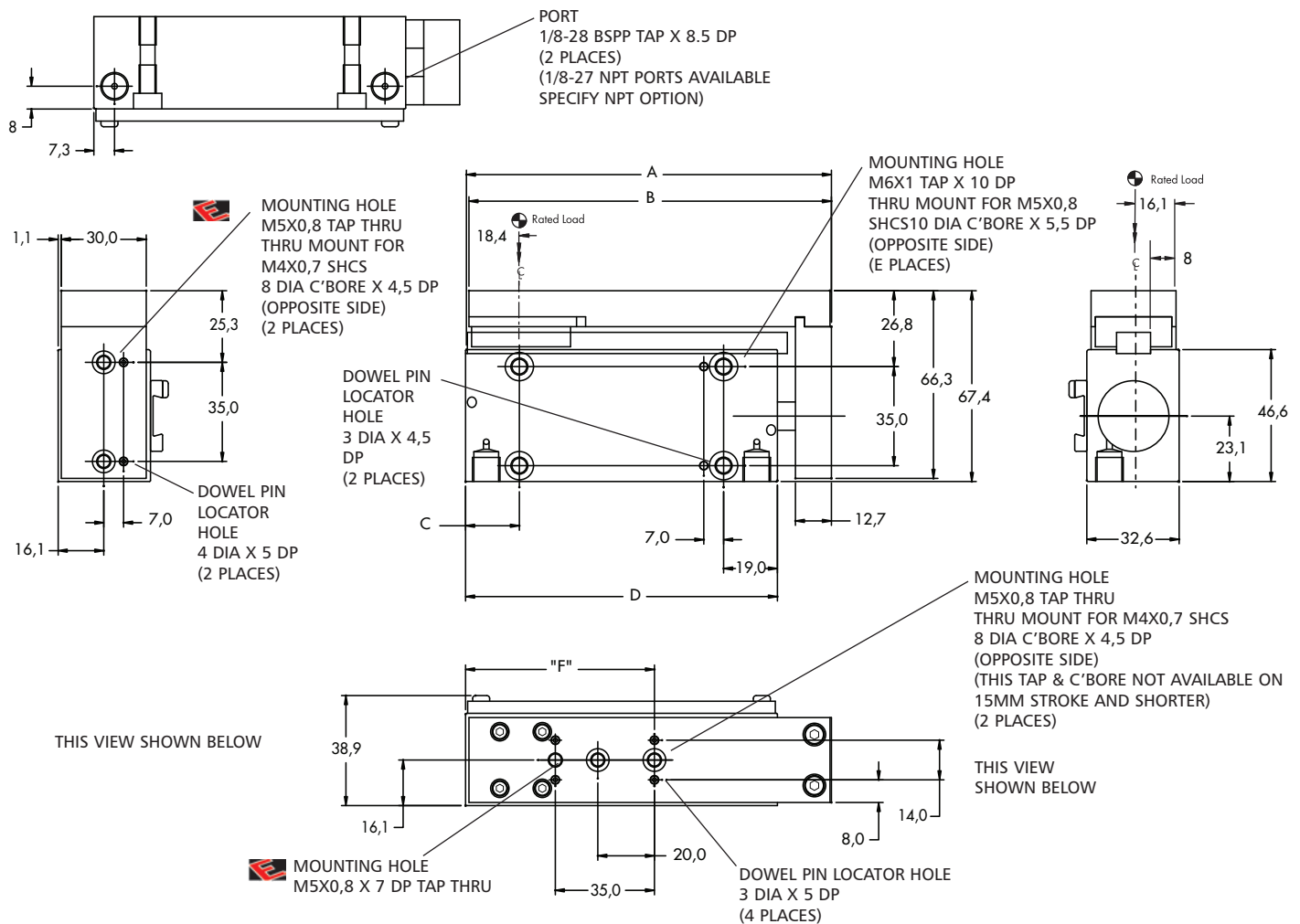
First Angle Projection





Easy Multi-Axis Assemblies

Both surfaces on the plate have mounting patterns:

Pattern 1:
Adapts to a BSC1000 Series mounting platform - or - a BSC2000 Series, Style 'B' cylinder, both of the same bore size. Also can be used for general purpose mounting.

Pattern 2:
Adapts to a BSC2000 Series, Style 'B' cylinder of the same bore size. Also can be used for

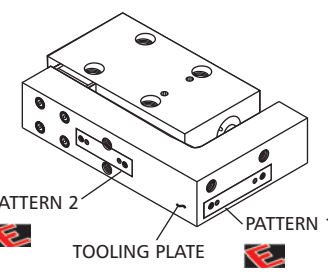

PATTERN 2

TOOLING PLATE

PATTERN 1

Part Number	Standard Stroke Length (mm)	A	B	C	D
BSC2T25X	5 10 15	69,2	68,0	50,13	51,7
BSC2T25X	20 25 30	84,2	83,0	65,13	66,7
BSC2T25X	35 40 45 50	104,2	103,0	85,13	66,7
BSC2T25X	55 60 65 70 75	129,2	128,0	110,13	66,7
BSC2T25X	80 85 90 95 100	154,2	153,0	135,1	66,7
BSC2T25X	105 110 115 120 125	179,2	178,0	160,13	66,7
BSC2T25X	130 135 140 145 150	204,2	203,0	185,13	66,7

All dimensions shown in millimeters unless otherwise noted.

Dowel Pin Locator Holes are designed for location and additional shear strength.

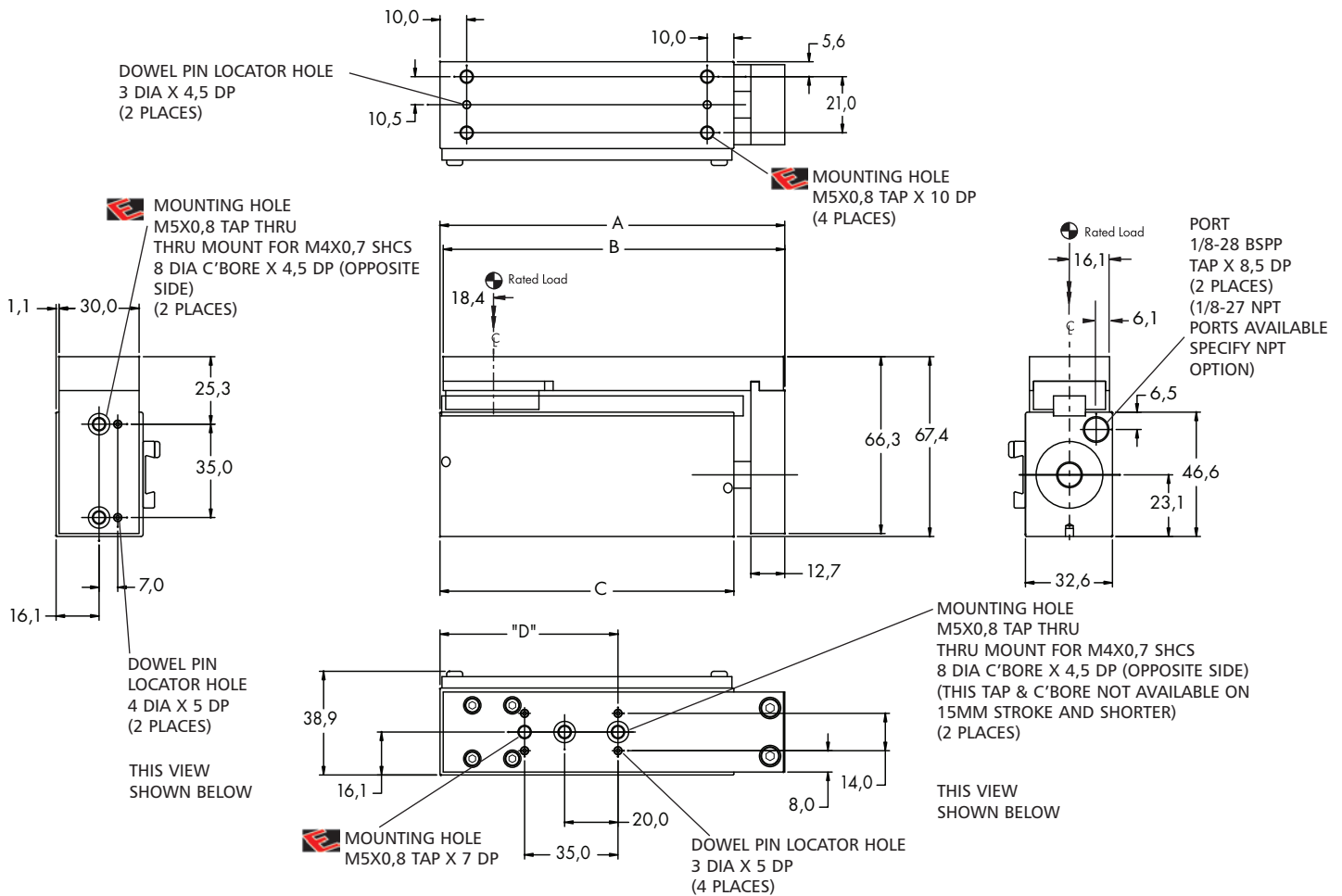
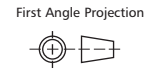

Easy Multi-Axis Assemblies

Both surfaces on the plate have mounting patterns:

Pattern 1:

Adapts to a BSC1000 Series mounting platform - or - a BSC2000 Series, Style 'B' cylinder, both of the same bore size. Also can be used for general purpose mounting.

Pattern 2:

Adapts to a BSC2000 Series, Style 'B' cylinder of the same bore size. Also can be used for

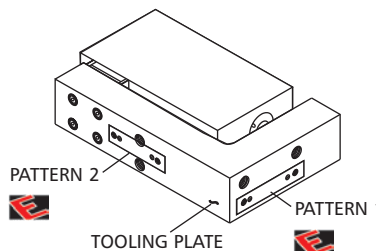

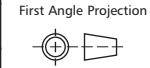

Part Number	Standard Stroke Length (mm)	A	B	C
BSC2S40X	5 10 15 20 25 30	92,0	87,5	71,1
BSC2S40X	35 40 45 50	112,0	107,5	91,1
BSC2S40X	55 60 65 70 75	137,0	132,5	116,1
BSC2S40X	80 85 90 95 100	162,0	157,5	141,1
BSC2S40X	105 110 115 120 125 130 135 140 145 150	212,0	207,5	191,1
BSC2S40X	155 160 165 170 175 180 185 190 195 200	262,0	257,5	241,1

Dowel Pin Locator Holes are designed for location and additional shear strength.

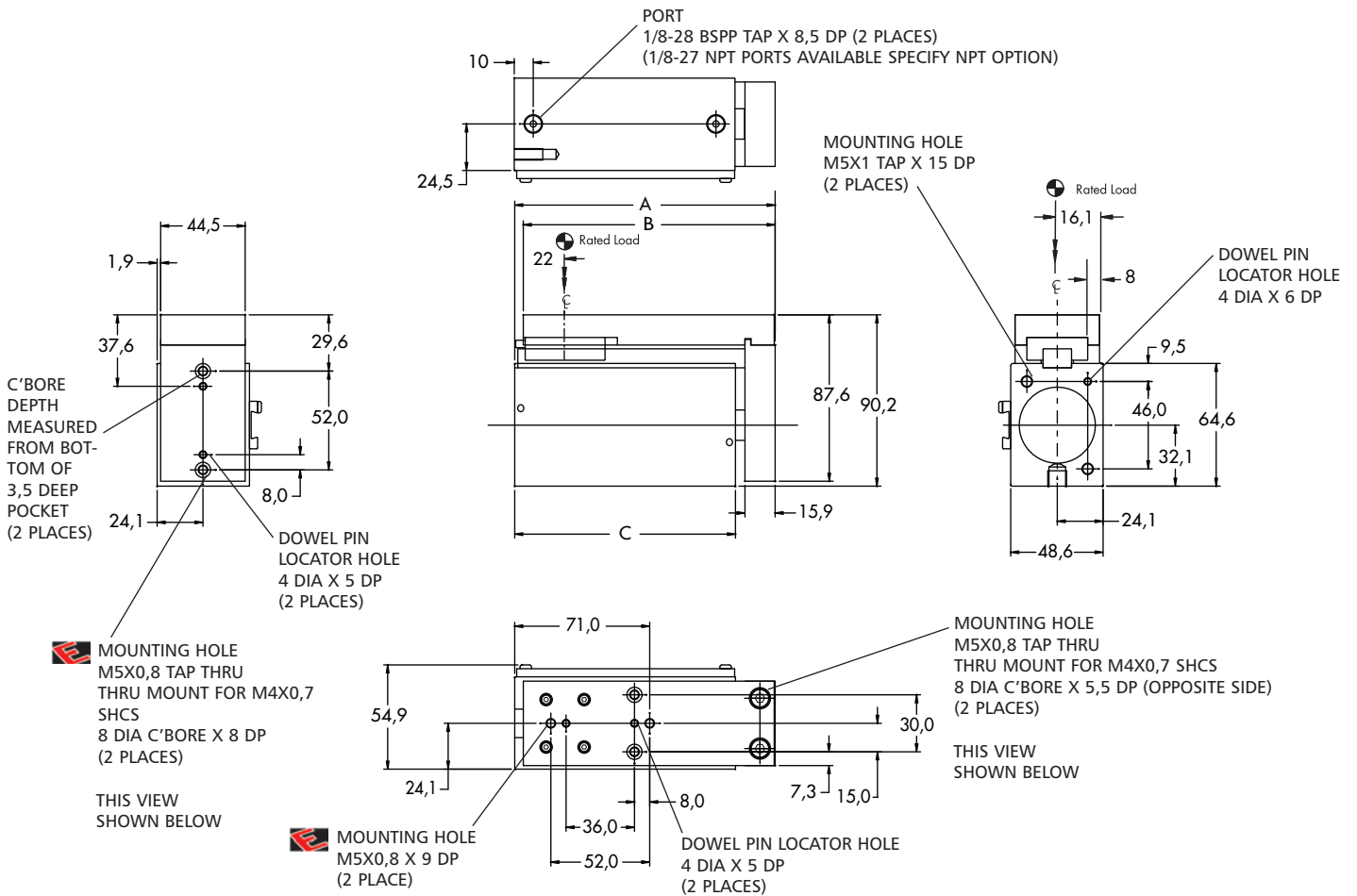

All dimensions shown in millimeters unless otherwise noted.





Easy Multi-Axis Assemblies

Both surfaces on the plate have mounting patterns:

Pattern 1:
Adapts to a BSC2000 Series, Style 'B' cylinder, both of the same bore size. Also can be used for general purpose mounting.

Pattern 2:
Adapts to a BSC2000 Series, Style 'B' cylinder of the same bore size. Also can be used for general purpose mounting.

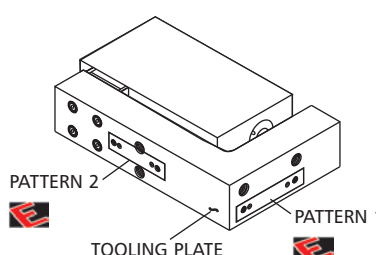

PATTERN 2

TOOLING PLATE

PATTERN 1

Part Number	Standard Stroke Length (mm)	A	B	C	D	E
BSC2B40X	5 10 15 20 25 30	92,0	87,5	---	71,13	2
BSC2B40X	35 40 45 50	112,0	107,5	21,0	91,13	4
BSC2B40X	55 60 65 70 75	137,0	132,5	21,0	116,13	4
BSC2B40X	80 85 90 95 100	162,0	157,5	21,0	141,13	4
BSC2B40X	105 110 115 120 125 130 135 140 145 150	212,0	207,5	21,0	191,13	4
BSC2B40X	155 160 165 170 175 180 185 190 195 200	262,0	257,5	21,0	241,13	4

Dowel Pin Locator Holes are designed for location and additional shear strength.

First Angle Projection



All dimensions shown in millimeters unless otherwise noted.

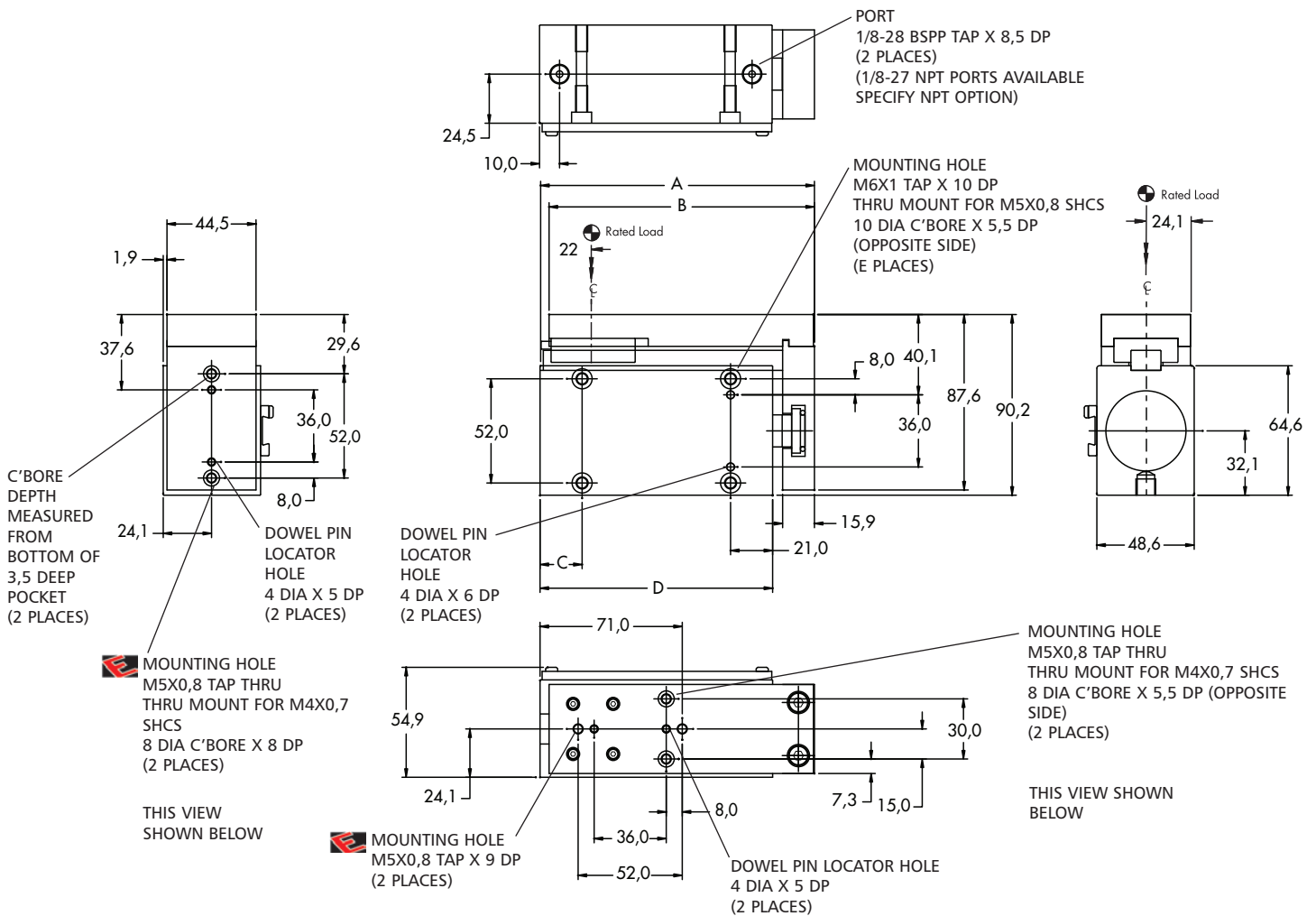



Easy Multi-Axis Assemblies

Both surfaces on the plate have mounting patterns:

Pattern 1:
Adapts to a BSC2000 Series, Style 'B' cylinder, both of the same bore size. Also can be used for general purpose mounting.

Pattern 2:
Adapts to a BSC2000 Series, Style 'B' cylinder of the same bore size. Also can be used for general purpose mounting.

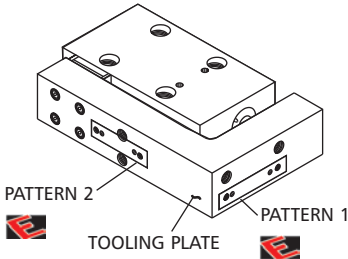

PATTERN 2
TOOLING PLATE
PATTERN 1

Part Number	Standard Stroke Length (mm)	A	B	C
BSC2T40X_	5 10 15 20 25 30	92,0	87,5	71,13
BSC2T40X_	35 40 45 50	112,0	107,5	91,13
BSC2T40X_	55 60 65 70 75	137,0	132,5	116,13
BSC2T40X_	80 85 90 95 100	162,0	157,5	141,13
BSC2T40X_	105 110 115 120 125 130 135 140 145 150	212,0	207,5	191,13
BSC2T40X_	155 160 165 170 175 180 185 190 195 200	262,0	257,5	241,13

Dowel Pin Locator Holes are designed for location and additional shear strength.

First Angle Projection



All dimensions shown in millimeters unless otherwise noted.

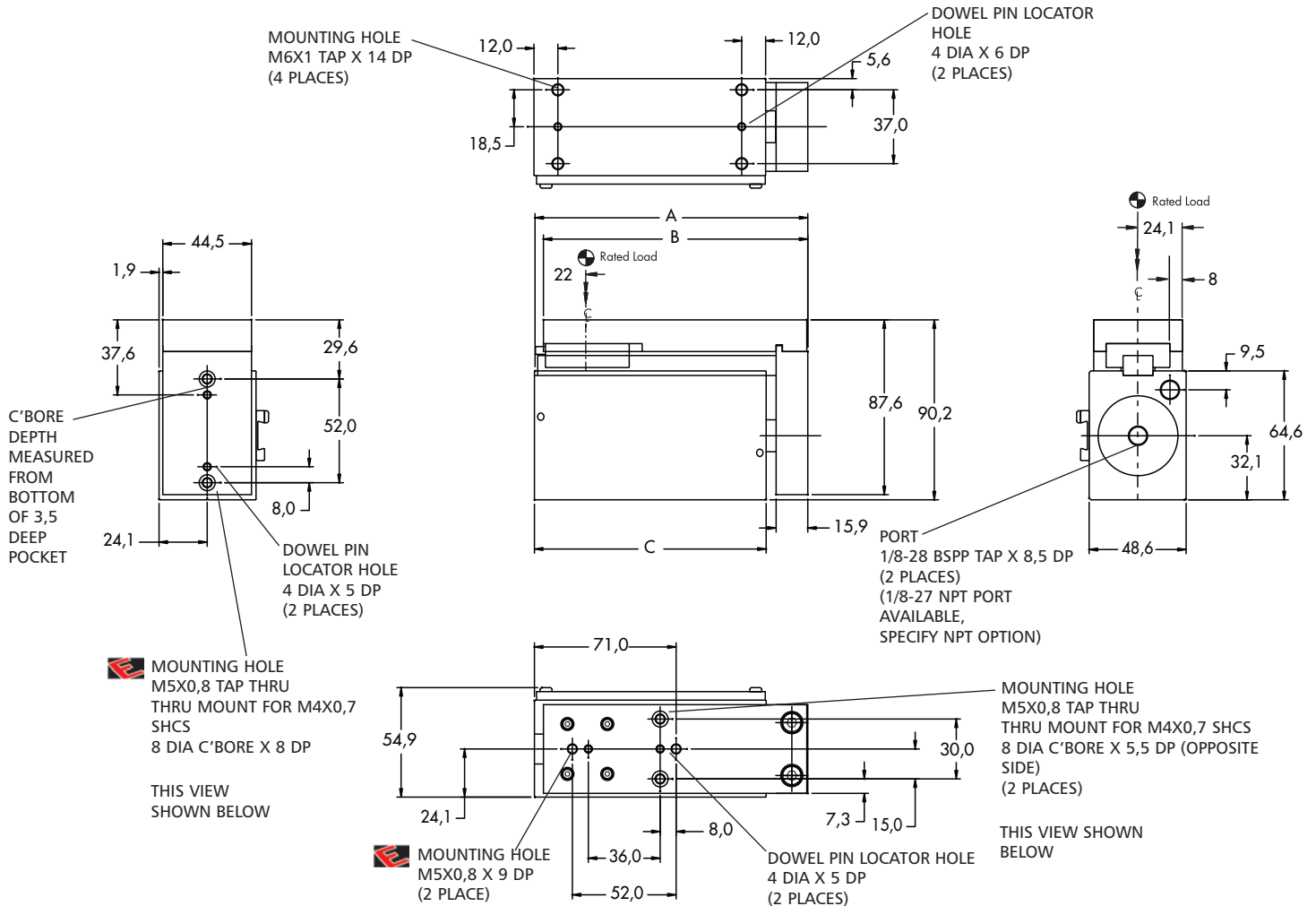

Easy Multi-Axis Assemblies

Both surfaces on the plate have mounting patterns:

Pattern 1:

Adapts to a BSC2000 Series, Style 'B' cylinder, both of the same bore size. Also can be used for general purpose mounting.

Pattern 2:

Adapts to a BSC2000 Series, Style 'B' cylinder of the same bore size. Also can be used for general purpose mounting.

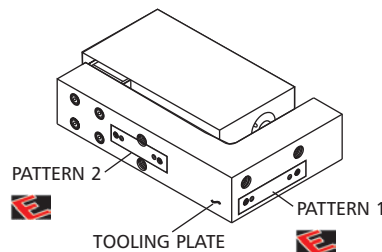

BSC2000 Series Load Ratings

Moment Loads

Bore Size	Stroke (mm)	Push Max. kgf (lbf)	Pull Max. kgf (lbf)	Coefficient of friction	C Basic Dynamic Load Rating kgf (lbf)	Co Basic Static Load Rating kgf (lbf)	Ma kgf*m (lbf*in) static	Da mm (in)	Mb kgf*m (lbf*in) static	Mc kgf*m (lbf*in) static	Dc mm (in)
8mm	2,5-15	4,25 (9.36)	3,2 (7.02)	See *Note Below	32 (72)	60 (132)	0,06 (5)	36,5	0,06 (5)	0,07 (6)	8 (.315)
	17,5-30							51,5			
12mm	2,5-15	9 (19.89)	6,9 (15.21)	See *Note Below	90 (198)	140 (308)	0,1 (8.7)	38,5	0,1 (8.7)	0,15 (13)	11 (.433)
	17,5-30							53,5			
	32,5-50							73,5			
20mm	5-15	47 (104)	39,5 (87)	See *Note Below	150 (330)	230 (506)	0,2 (17)	48	0,2 (17)	0,3 (26)	13 (5.1)
	20-30							63			
	35-50							83			
	55-75							108			
25mm	5-15	75 (165)	63 (139)	See *Note Below	270 (595)	410 (903)	0,5 (43.4)	49,6 (1.95)	0,5 (43.4)	1 (86.8)	15,9 (.63)
	20-30							64,6 (2.54)			
	35-50							84,6 (3.33)			
	55-75							109,6 (4.31)			
	80-100							134,6 (5.3)			
	105-125							159,6 (6.28)			
	130-150							184,6 (7.27)			
40	5-30	192 (423)	161 (355)	See *Note Below	450 (992)	670 (1477)	1 (86.8)	65,5	1 (86.8)	2 (173.6)	22,2 (.875)
	35-50							85,5			
	55-75							110,5			
	80-100							135,5			
	105-150							185,5			
	155-200							235,5			
*Note:	Theoretical coefficient of friction of the bearing for loads $\geq .05C$ is $\leq .004$. Increased frictional resistance due to moment loads and the frictional resistance of the cylinder are additional to the bearing resistance.										

BSC2000 Series Load Ratings

Moment Loads

Downward basic loads equal C and Co. For lateral loading, dynamic load rating equals 0,82 C and static load rating equals 0,76 Co. For upward loading, dynamic load rating equals 0,78 C and static load rating equals 0,70 Co.

The slide does not increase the push or pull capabilities of the pneumatic system. Flow controls are recommended to improve the life of the overall system if high loads and/or speeds are expected. Basic dynamic load rating of the slide is defined as a load whose direction and magnitude are constant and under which 90% of the slides traveled 50 x 10³ meters (1.9 million inches) without suffering from material damage due to rolling contact fatigue. Life is increased when moment loads are observed.

Basic static load rating of the slide is defined as the static load which gives a prescribed contact stress at the center of contact area between the rolling element and the raceway which are receiving the maximum load.

Basic loads and moment arm lengths are assumed centered on slide carriage. Moment and load directions are as illustrated:

La, Lb and Lc are distances from tooling plate to loading point.

Formulas for allowable static loads in kg:

$$F_a = \frac{M_a(1000)}{L_a + D_a}$$

$$F_b = \frac{M_b(1000)}{L_b + D_a}$$

$$F_c = \frac{M_c(1000)}{L_c + D_c}$$

For example: 20mm x 30mm Stroke

Part No.: BSC2_20x30

↳ (Specify S, B or T)

Da = 63mm Dc = 13mm

If La, Lb, or Lc = 0

$$\text{Then: } F_a = \frac{.2(1000)}{63} = 3,2 \text{ kgf} = 7 \text{ lbf}$$

$$F_b = \frac{.2(1000)}{63} = 3,2 \text{ kgf} = 7 \text{ lbf}$$

$$F_c = \frac{.3(1000)}{13} = 23 \text{ kgf} = 51 \text{ lbf}$$

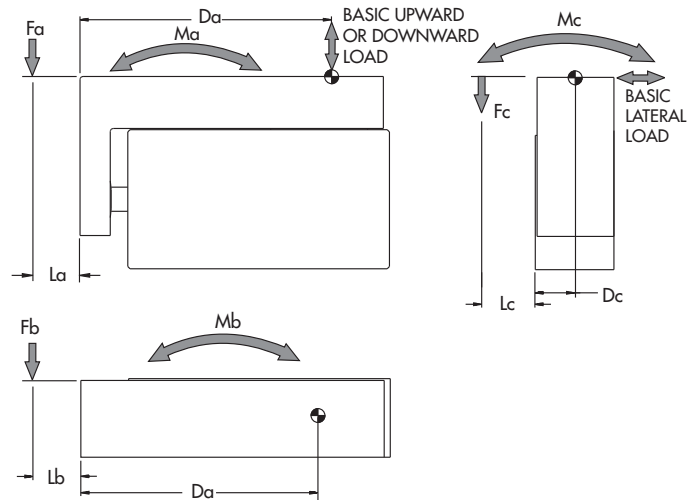

CAUTION!

Forces resulting from inertia must be considered in your application.

Use equipment within specifications.

Reference:

1 kgf = 9,807N = 2.2046 lbf

1 mm = .03937 in

1 kgf*m = 9,807 N*m

1 lbf*in = 0,0115 kgf*m

1 kgf*m = 86.8 lbf*in

MPA

Available on all BSC1000 Series and BSC2000 Series, B style only

Multi-Position Cylinder

Concept: BSC2 'B' style shown

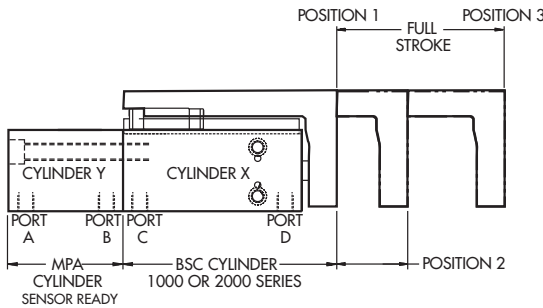

Example:

1. Fully retracted, *position 1*
2. Usually a low constant pressure is applied to Port D, to prevent over travel or backlash in the middle increment
3. Send normal pressure to Port A, *position 2*
4. Send normal pressure to Port C, *position 3*
5. By relieving pressure to Port A and Port C unit will retract, note 2 - or - you can retract unit via Port D with full pressure
6. Port B is a vent only

7. Consult your local distributor to work through this schematic. They can also advise you on other control valve techniques for your specific application.

Multi-Piston Cylinder

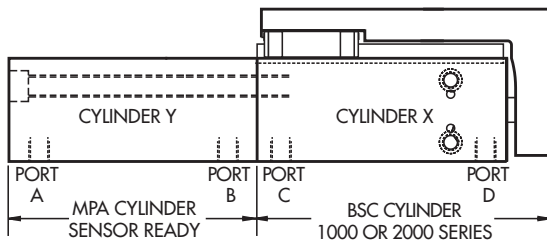

Example: 12mm Bore

1. Air pressure to port D fully retracts the cylinder with the power of one piston. *Piston Area 85mm²*
2. The power of the piston is increased when air is supplied simultaneously to ports A and C. *Piston Area 198mm² (two cylinders)*
3. Use 'Dimensional Information' on the following page for reference.
4. Standard 4 way valve circuit
5. Port B is a vent only

MPA__

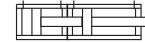

Factory Assembled and tested

Ordering Suffix:
Stroke length:

MPA__
Must be shorter than BSC cylinder stroke specified
BSC2B12x25MPA10

Ordering Example:

Cylinder X = Ball Slide Cylinder which contains full stroke
Cylinder Y = Cylinder Multi Position Cylinder which creates position 2, Cylinder Y internally pushes Cylinder X piston forward

Piston Area mm² (in²)

Bore	8	12	20	25	40
Push	50 (.08)	113 (.17)	314 (.49)	491 (.76)	1257 (1.94)
Pull	37 (.06)	85 (.13)	263 (.40)	412 (.64)	1056 (1.64)

Reference: Dimensional Information on the following page

MPA__

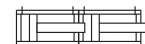

Ordering Suffix:
Stroke length:

MPA__
Must be the same stroke length as the BSC cylinder stroke specified
BSC2B12x25MPA25

Ordering Example:

Cylinder X = Ball Slide cylinder
Cylinder Y = Cylinder Multi-Piston cylinder with the same stroke as the Ball Slide Cylinder

Piston Area mm² (in²)

Bore	8	12	20	25	40
Push	87 (.14)	198 (.3)	577 (.89)	903 (1.40)	2313 (3.58)
Pull	37 (.06)	85 (.13)	263 (.40)	412 (.64)	1056 (1.64)

Reference:
Dimensional Information on the following page

MPA /Additional Option

MPA Option - Dimensional Information

Stroke increments are obtained using internal spacers in the 'MPA' cylinder option.

Consult the factory with any questions.

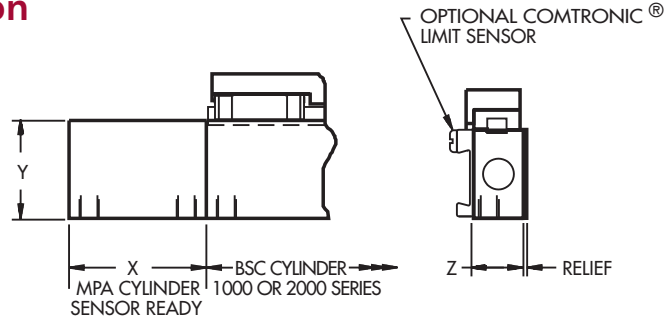

8mm Bore	Standard Stroke Length	X	Y	Z
BSC1000 or BSC2000-Style B only	2,5 5 7,5 10 12,5 15	38	23	12,6
	17,5 20 22,5 25 27,5 30	53		
12mm Bore	Standard Stroke Length	X	Y	Z
BSC1000 or BSC2000-Style B only	2,5 5 7,5 10 12,5 15	41	25,4	18,6
	17,5 20 22,5 25 27,5 30	56		
	32,5 35 37,5 40 42,5 45 47,5 50	76		
20mm Bore	Standard Stroke Length	X	Y	Z
BSC1000 or BSC2000-Style B only	5 10 15	45	39	25,6
	20 25 30	60		
	35 40 45 50	80		
	55 60 65 70 75	105		
25mm Bore	Standard Stroke Length	X	Y	Z
BSC1000 or BSC2000-Style B only	5 10 15	51.7	47	33
	20 25 30	66.7		
	35 40 45 50	66.7		
	55 60 65 70 75	66.7		
	80 85 90 95 100	66.7		
	105 110 115 120 125	66.7		
	130 135 140 145 150	66.7		
40mm Bore	Standard Stroke Length	X	Y	Z
BSC1000 or BSC2000-Style B only	5 10 15 20 25 30	71.13	65	49
	35 40 45 50	91.13		
	55 60 65 70 75	116.13		
	80 85 90 95 100	141.13		
	105 110 115 120 125 130 135 140 145 150	191.13		
	155 160 165 170 175 180 185 190 195 200	241.13		

MPA / Additional Options

Flow Controls

Metered out flow controls only

Port	A	B
M5	15	15,1
G18	25,4	23,4

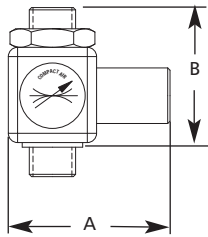

Installation locations:

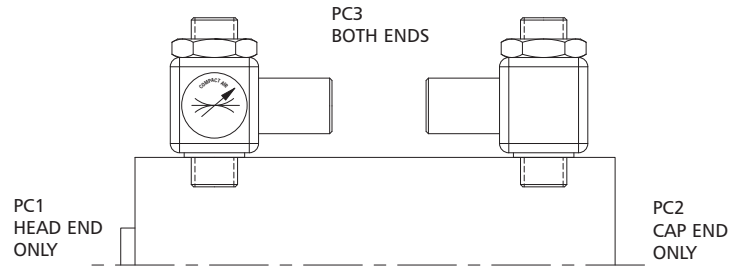

Factory Installed Option

PC__

Example: PC1, PC2, or PC3

Ordering Suffix PC__

Hydraulic Seals

Seal material is Nitrile and Urethane. Moderate resistance to abrasion, high pressure and shock. Low temperature decreases flexibility.

Note: 20, 25, and 40mm bore only

HYD

Ordering Prefix:

HYD

Material:

Nitrile and Urethane

Rating:

-20°C - 120°C

(0°F - 250°F)

Application Specific

Modified Ball Slide Cylinder Examples

Consult the factory with your unique ball slide application. We can promptly quote a cylinder with your custom requirements.

Examples include:

- Extra high load capacities
- Double carriages
- Custom tooling plates, sliding element brackets
- Multi-axis assemblies
- Larger bore sizes
- Longer stroke lengths

Sensors

Standard Limit Sensors

- Low Cost and compact size
- Dual LED indicators for power and signal
- Circuit protection/surge and polarity
- High-flex robotic grade cable with 4.8mm (3/16") bend radius. 105 strand primaries.
- CE compliant / IP67 and NEMA 6 rated
- 100% solid state device for maximum life
- 3 cord options

(Shown with Quick Disconnect Option)



Part No.		Sensor Type (Wiring diagrams and definitions on page 5)	Cord Types		
			Quick Disconnect	1 Meter	3 Meter
Sinking	WSKL	NPN		✓	
	WSKLP		✓ *		
	WSKL3				✓
	WSKLPS		✓ *		
Sourcing	WSCL	PNP		✓	
	WSCLP		✓ *		
	WSCL3				✓
	WSCLPS		✓ *		

*NOTE: Mating 3 socket receptacle available, part number R3.

Optional Quick Disconnect Sensor Cable

with threaded, sealed connectors Part Number - Specify K or C

3 Prong Plug

#WSKLP, #WSCLP,
#WSKLPS, #WSCLPS

WS_LP

WS_LPS

"3" denotes 3 meter cable

3 Socket Receptacle

Part Number

For use with:

#WSKLP, #WSCLP, #WSKLPS, #WSCLPS,
#HSK, #HSC, #WSKLRPS, #WSCLRPS

R3



Sold Separately

Part Number

R3

Receptacle - 3 Socket

Plug - 3 Prong

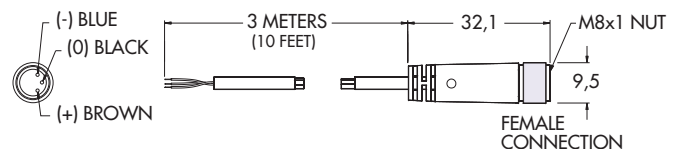
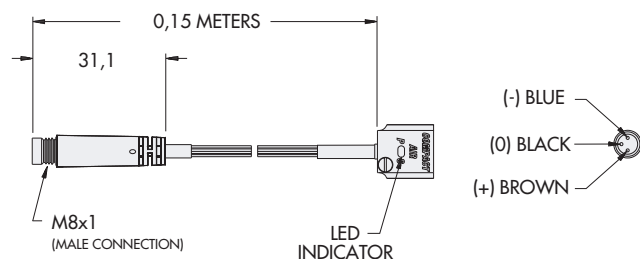

Sensors

Comtronic® Sensors Dimensional Information

Must specify 'K' (sinking) or 'C' (sourcing) when ordering

Part Number - Specify K or C

WS_L

WS_L3

"3" denotes 3 meter cable

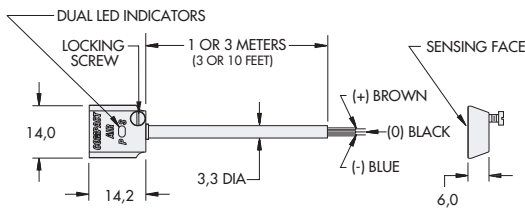

Part No. WSKL-3 - Sinking output with 3 meter cable.



Specifications		
Parameters	Compact® Standard Limit Sensors	
	NPN (sinking)	PNP (sourcing)
Part Number	WSKL, WSKL3, WSKLP, WSKLPS	WSCL, WSCL3, WSCLP, WSCLPS
Operating Voltage	5-24 VDC	
Current Consumption On	16mA (24V)	14mA (24V)
Off	7mA (24V)	7mA (24V)
Switching Current	100mA Max	
Voltage Drop	1.5 V Max @ 100mA	
Operating Frequency	1 KHz Max	
Switch Logic	Sinking, Normally Open	Sourcing, Normally Open
LED Function Green	Power On	
Red	Switch Active	
Operating Temperature	0°C to 70°C	
Circuit Protection	Reverse/Polarity / Surge Absorber	
Environmental	IEC standard IP67, NEMA 6P	
Wire Type	High flex, 24 AWG / 105 strand primary	
Housing Material	Zinc diecast	
Housing Color Code	Black	Silver
Shock Resistance	30G Max	
Vibration Strength	9G Max	

Wiring Diagrams and Definitions

For units with flying leads

NPN Output Sinking (K)

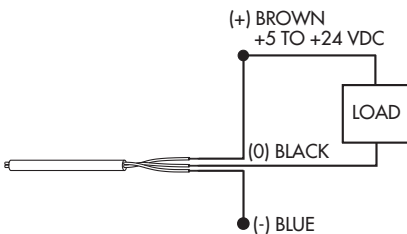

- Ideal for complex controls utilizing multiple power supplies.

A "sinking" output sensor complete a circuit by connecting the load to ground. Sinking output sensors in a sequence can have different supply voltages. The ground is their common factor.

PNP Output Sourcing (C)

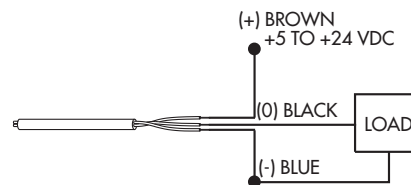

- Ideal for single power supply applications.

A "sourcing" output sensor completes a circuit by connecting the load to the supply current. All sourcing output sensors must have the same supply voltage.

Life Calculation by Nomograph

BSC1000 Series or BSC2000 Series - Any stroke length

Rated life of the sliding element can be readily calculated from following graph:

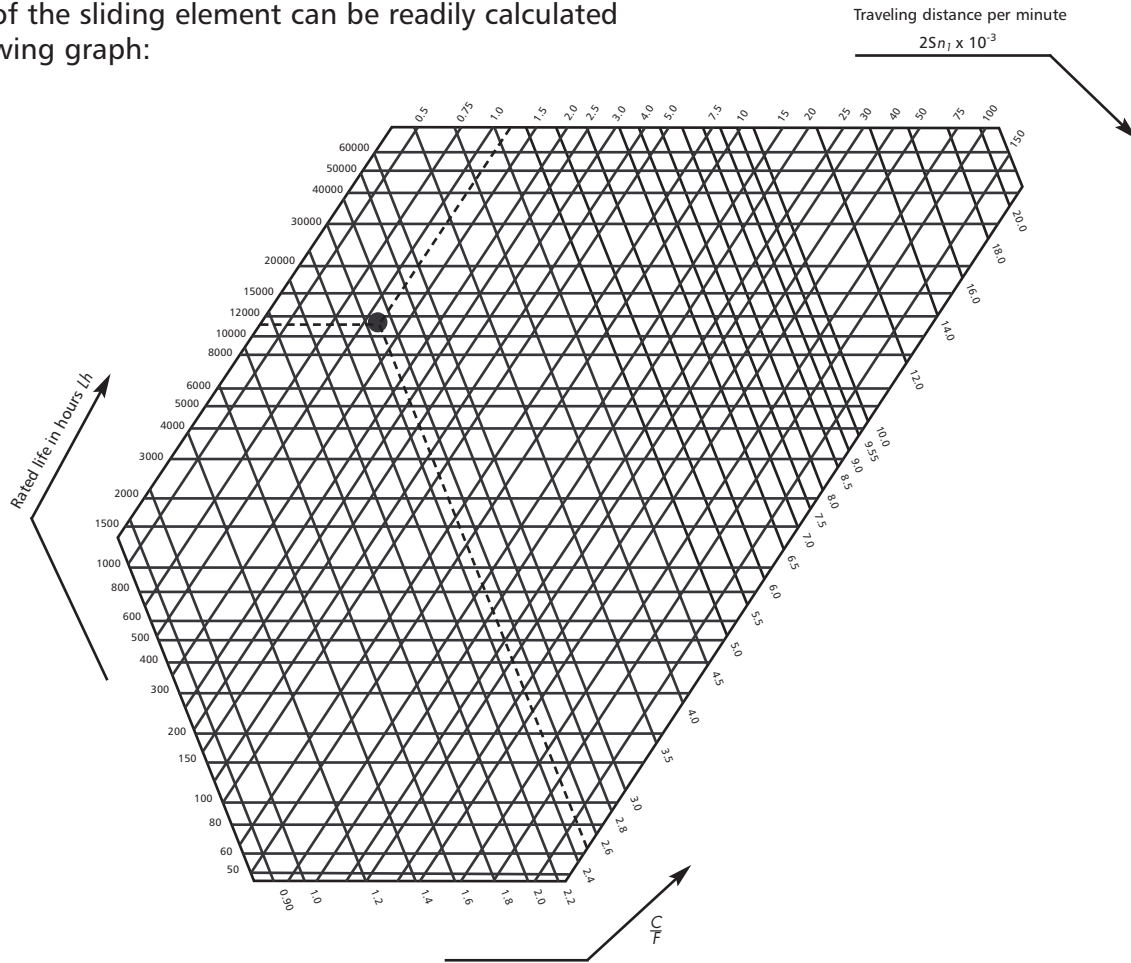

- C: Basic dynamic load rating, kgf
- F: Applied load, kgf
- $F = f_w FC$
- f_w : Load factor (see Load Correction Factors page)
- F_c : Theoretically calculated load, kgf
- S: Stroke length, mm
- n_1 : Number of strokes per minute, cpm
- L_h : Rated life in hours

Note: Nomograph estimates life expectancy of the ball slide element only. Life expectancy of additional elements such as, actuator, flow controls or seals is not derated according to these calculations.

Example: Calculation of the rated life of BSC2B20x30 under the following operating conditions:

Downward load: 60 kgf

Stroke length: 30mm

Number of strokes per minute: 20 cpm

The basic dynamic load rating of this rolling guide is

$C = 150\text{kgf}$ (see BSC2 Load Rating pages) and the downward load is

$F = 60\text{ kgf}$

Therefore, $\frac{C}{F} = \frac{150}{60} = 2.5$

$2 S n_1 \times 10^{-3} = 2 \times 30 \times 20 \times 10^{-3} = 1.2$

On the above nomograph, from the intersection point of the line $C/F = 2.5$ and the line $2S n_1 \times 10^{-3} = 1.2$, the rated life in hours, L_h , can be obtained as approximately 11000 hours.

Load Correction Factor

Safety Correction Factor, f_s

$$f_s = \frac{C_o}{C_s}$$

Where: f_s = Safety factor
 C_o = Basic static load rating
 (see Load Rating pages)
 C_s = Static Load

Safety Factors (f_s)			
Impact and Vibrations	Speed (V)	Measured Vibrations (G)	f_s
Without external impacts or vibrations	At low speed $V \leq 15$ (m/min)	Corresponding acceleration $\leq 0.5G$	1~3
Without significant impact or vibrations	At medium speed $15 < V \leq 60$ (m/min)	$0.5 < G \leq 1.0$	2~4
With external impact and vibrations	At high speed $V > 60$ (m/min)	$1.0 < G \leq 2.0$	3~5

Ball Slide Cylinder Weights

Weights by Bore Size and Series

8mm Bore BSC1		8mm Bore BSC2	
Stroke	Weight	Stroke	Weight
2,5-15	2.5 OZ	2,5-15	2.5 OZ
17,5-30	3 OZ	17,5-30	3 OZ

12mm Bore BSC1		12mm Bore BSC2	
Stroke	Weight	Stroke	Weight
2,5-15	5 OZ	2,5-15	4 OZ
17,5-30	6 OZ	17,5-30	5 OZ
32,5-50	7 OZ	32,5-50	6 OZ

20mm Bore BSC1		20mm Bore BSC2	
Stroke	Weight	Stroke	Weight
5-15	11.5 OZ	5-15	9 OZ
20-30	13 OZ	20-30	10.5 OZ
35-50	15.5 OZ	35-50	12.5 OZ
55-75	1 LB 3 OZ	55-75	15 OZ

25mm Bore BSC1		25mm Bore BSC2	
Stroke	Weight	Stroke	Weight
5-15	1 LB 2 OZ	5-15	13.5 OZ
20-30	1 LB 5 OZ	20-30	1 LB
35-50	1 LB 8.5 OZ	35-50	1 LB 3.5 OZ
55-75	1 LB 13.5 OZ	55-75	1 LB 8 OZ
80-100	2 LB 2.5 OZ	80-100	1 LB 12.5 OZ
105-125	2 LB 7.5 OZ	105-125	2 LB 1 OZ
130-150	2 LB 12.5 OZ	130-150	2 LB 5.5 OZ

40mm Bore BSC1		40mm Bore BSC2	
Stroke	Weight	Stroke	Weight
20-30	2 LB 14.5 OZ	20-30	2 LB 2.5 OZ
35-50	3 LB 6 OZ	35-50	2 LB 9 OZ
55-75	3 LB 15.5 OZ	55-75	3 LB 1.5 OZ
80-100	4 LB 11 OZ	80-100	3 LB 9.5 OZ
105-150	5 LB 12 OZ	105-150	4 LB 10.5 OZ
155-200	6 LB 15 OZ	155-200	5 LB 11 OZ
205-250	8 LB 2 OZ	205-250	6 LB 12 OZ
255-300	9 LB 1 OZ	255-300	6 LB 12 OZ

Special Conditions and Limited Warranty

Determination of the suitability of any information or product for the application contemplated by any user or the manner of that use is the sole responsibility of the user.

Compact Automation Products, LLC reserves the right to improve or change designs without notice.

All orders are subject to acceptance by the factory sales department.

Compact Automation Products, LLC agrees to repair or replace to the original purchaser any standard parts or products for a period of 12 months from date of shipment which Compact Automation Products, LLC determines upon inspection to be defective in workmanship or material. Wear components including but not limited to seals and bearings are excluded from this warranty.

Under no circumstance may merchandise be returned without written authorization from the factory.

This warranty is void in the event the product has been tampered with, altered, or serviced by unauthorized personnel.

Compact Automation Products, LLC's total responsibility for any claims, damages, losses or liabilities related to the product covered thereunder shall not exceed the purchase price of such product. In no event shall Compact Automation Products, LLC be liable for any special, indirect, incidental or consequential damages of any character, including but not limited to loss of use of productive facilities or equipment, lost profit, property damage, transportation, installation or removal or lost production whether suffered by purchaser or third party. Compact Automation Products, LLC disclaims all liability for any and all cost, claims demands, charges, expenses, and other damages, either direct or indirect, incident to all property damage arising out of any cause of action based on strict liability. This warranty gives you specific legal rights and you may have other rights, which vary from state to state.

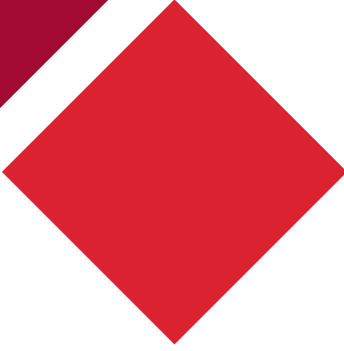
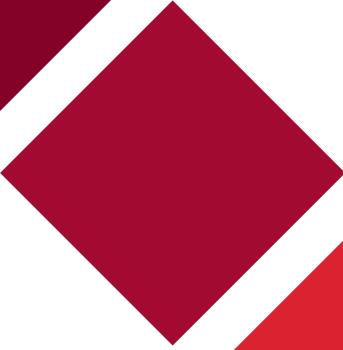

COMPACT[®]
AUTOMATION PRODUCTS

Compact Automation Products, LLC
105 Commerce Way
Westminster, SC 29693
Tel: 864.647.9521
Fax: 864.647.9574
www.compactautomation.com